

TOSHIBA

User's Manual

A40

TOSHIBA

A A40 TOSHIBA A40 TOSHIBA A40 TOSHIBA A40

Choose freedom.
computers.toshiba-europe.com

TOSHIBA

Copyright

© 2003 by TOSHIBA Corporation. All rights reserved. Under the copyright laws, this manual cannot be reproduced in any form without the prior written permission of TOSHIBA. No patent liability is assumed, with respect to the use of the information contained herein.

TOSHIBA A40 Series Portable Personal Computer User's Manual

First edition December 2003

Disclaimer

This manual has been validated and reviewed for accuracy. The instructions and descriptions it contains are accurate for the TOSHIBA A40 Series Portable Personal Computer at the time of this manual's production. However, succeeding computers and manuals are subject to change without notice. TOSHIBA assumes no liability for damages incurred directly or indirectly from errors, omissions or discrepancies between the computer and the manual.

Trademarks

Intel, Intel Speed Step, Pentium and Celeron are trademarks or registered trademarks of Intel Corporation.

Windows and Microsoft are registered trademarks of Microsoft Corporation.

Photo CD is a trademark of Eastman Kodak.

i.LINK is a trademark of Sony Corporation.

TruSurround XT, TruBass, Dialog Clarity, SRS and symbol are trademarks of SRS Labs, Inc.

TruSurround XT technology is incorporated under license from SRS Labs, Inc.

Other trademarks and registered trademarks not listed above may be used in this manual.

EU Declaration of Conformity



This product carries the CE-Mark in accordance with the related European Directives. CE-Marking is the responsibility of TOSHIBA Europe GmbH, Hammfelddamm 8, 41460 Neuss, Germany. The complete and official EU Declaration of Conformity can be found on TOSHIBA's web site <http://epps.toshiba-teg.com> on the Internet.

Modem warning notice

Conformity Statement

The equipment has been approved to [Commission Decision "CTR21"] for pan-European single terminal connection to the Public Switched Telephone Network (PSTN).

However, due to differences between the individual PSTNs provided in different countries/regions the approval does not, of itself, give an unconditional assurance of successful operation on every PSTN network termination point.

In the event of problems, you should contact your equipment supplier in the first instance.

Network Compatibility Statement

This product is designed to work with, and is compatible with the following networks. It has been tested to and found to conform with the additional requirements contained in EG 201 121.

Germany	- ATAAB AN005, AN006, AN007, AN009, AN010, and DE03, 04, 05, 08, 09, 12, 14, 17
Greece	- ATAAB AN005, AN006 and GR01, 02, 03, 04
Portugal	- ATAAB AN001, 005, 006, 007, 011 and P03, 04, 08, 10
Spain	- ATAAB AN005, 007, 012, and ES01
Switzerland	- ATAAB AN002
All other countries/regions	- ATAAB AN003, 004

Specific switch settings or software setup are required for each network, please refer to the relevant sections of the user guide for more details.

The hookflash (timed break register recall) function is subject to separate national type approval. It has not been tested for conformity to national type regulations, and no guarantee of successful operation of that specific function on specific national networks can be given.

Optical disc drive safety instructions



Be sure to check the international precautions at the end of this section.

TEAC

CD-RW/DVD-ROM DW-224E



The CD-RW/DVD-ROM drive employs a laser system. To ensure proper use of this product, please read this instruction manual carefully and retain for future reference. Should the unit ever require maintenance, contact an authorized service location.

Use of controls, adjustments or the performance of procedures other than those specified may result in hazardous radiation exposure.

To prevent direct exposure to the laser beam, do not try to open the enclosure.

Location of the required label

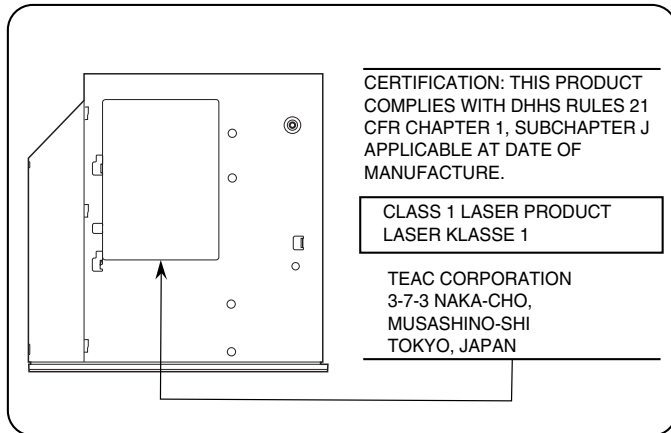

TOSHIBA

DVD-R/-RW SD-R6112



The DVD-R/-RW drive employs a laser system. To ensure proper use of this product, please read this instruction manual carefully and retain for future reference. Should the unit ever require maintenance, contact an authorized service location.

Use of controls, adjustments or the performance of procedures other than those specified may result in hazardous radiation exposure.

To prevent direct exposure to the laser beam, do not try to open the enclosure.

Location of the required label

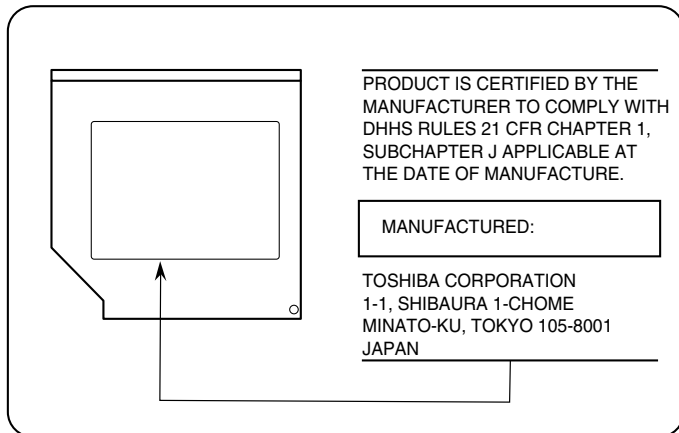

CD-RW/DVD-ROM SD-R2412



The CD-RW/DVD-ROM drive employs a laser system. To ensure proper use of this product, please read this instruction manual carefully and retain for future reference. Should the unit ever require maintenance, contact an authorized service location.

Use of controls, adjustments or the performance of procedures other than those specified may result in hazardous radiation exposure.

To prevent direct exposure to the laser beam, do not try to open the enclosure.

Location of the required label

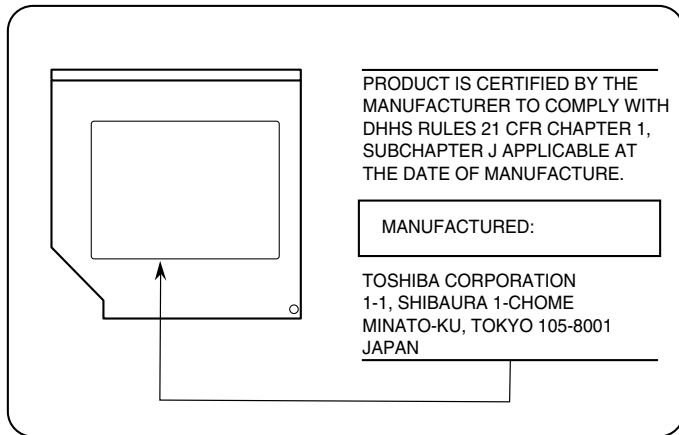

Panasonic

CD-RW/DVD-ROM UJDA750



The CD-RW/DVD-ROM drive employs a laser system. To ensure proper use of this product, please read this instruction manual carefully and retain for future reference. Should the unit ever require maintenance, contact an authorized service location.

Use of controls, adjustments or the performance of procedures other than those specified may result in hazardous radiation exposure.

To prevent direct exposure to the laser beam, do not try to open the enclosure.

Location of the required label

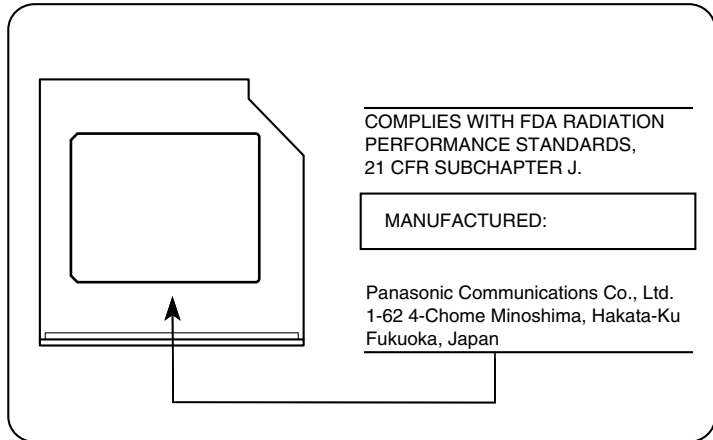

International precautions

CAUTION: This appliance contains a laser system and is classified as a "CLASS 1 LASER PRODUCT." To use this model properly, read the instruction manual carefully and keep this manual for your future reference. In case of any trouble with this model, please contact your nearest "AUTHORIZED service station." To prevent direct exposure to the laser beam, do not try to open the enclosure

VORSICHT: Dieses Gerät enthält ein Laser-System und ist als "LASERSCHUTZKLASSE 1 PRODUKT" klassifiziert. Für den richtigen Gebrauch dieses Modells lesen Sie bitte die Bedienungsanleitung sorgfältig durch und bewahren diese bitte als Referenz auf. Falls Probleme mit diesem Modell auftreten, benachrichtigen Sie bitte die nächste "autorisierte Service-Vertretung". Um einen direkten Kontakt mit dem Laserstrahl zu vermeiden darf das Gerät nicht geöffnet werden.

ADVARSEL: Denne mærking er anbragt udvendigt på apparatet og indikerer, at apparatet arbejder med laserstråler af klasse 1, hvilket betyder, at der anvendes laserstråler af svageste klasse, og at man ikke på apparatets yderside kan blive udsat for utilsigelig kraftig stråling.

APPARATET BOR KUN ÅBNES AF FAGFOLK MED SÆRLIGT KENDSKAB TIL APPARATER MED LASERSTRÅLER!

Indvendigt i apparatet er anbragt den her gengivne advarselmærkning, som advarer imod at foretage sådanne indgreb i apparatet, at man kan komme til at udsætte sig for laserstråling.

OBS! Apparaten innehåller laserkomponent som avger laserstråling överstigande gränsen för laserklass 1.

VAROITUS. Suojakoteloä si saa avata. Laite sisältää laserdiodin, joka lähetää näkymätöntä silmilie vaarallista lasersäteilyä.

CAUTION: USE OF CONTROLS OR ADJUSTMENTS OR PERFORMANCE OF PROCEDURES OTHER THAN THOSE SPECIFIED IN THE OWNER'S MANUAL MAY RESULT IN HAZARDOUS RADIATION EXPOSURE.

VORSICHT: DIE VERWENDUNG VON ANDEREN STEUERUNGEN ODER EINSTELLUNGEN ODER DAS DURCHFÜHREN VON ANDEREN VORGÄNGEN ALS IN DER BEDIENUNGSANLEITUNG BESCHRIEBEN KÖNNEN GEFÄHRLICHE STRAHLENEXPOSITIONEN ZUR FOLGE HABEN.

General Precautions

TOSHIBA computers are designed to optimize safety, minimize strain and withstand the rigors of portability. However, certain precautions should be observed to further reduce the risk of personal injury, damage to the computer or impaired performance.

Be certain to read the general precautions below and to note the cautions included in the text of the manual. Please also refer to the *Safety Instruction Manual*.

Stress injury

Carefully read the *Safety Instruction Manual*. It contains information on prevention of stress injuries to your hands and wrists that can be caused by extensive keyboard use. Chapter 3, *Getting Started*, also includes information on work space design, posture and lighting that can help reduce physical stress.

Heat Warning

- Avoid prolonged physical contact with the computer. If the computer is used for long periods, its surface can become very warm. While the temperature will not feel hot to the touch, if you maintain physical contact with the computer for a long time (if you rest the computer on your lap, or if you keep your hands on the palm rest, for example) your skin might suffer low-heat injury.
- If the computer has been used for a long time, avoid direct contact with the metal plate supporting the I/O ports. It can become hot.
- The surface of the AC adaptor can become hot when in use. This condition does not indicate a malfunction. If you need to transport the AC adaptor, disconnect it and let it cool before moving it.
- Do not lay the AC adaptor on a material that is sensitive to heat. The material could be damaged.

Pressure or impact damage

Do not apply heavy pressure to the computer or subject it to strong impact. Excessive pressure or impact can cause damage to computer components or otherwise cause malfunctions.

PC card overheating

Some PC cards can become hot with prolonged use. Overheating of a PC card can result in errors or instability in the PC card operation. Also be careful when you remove a PC card that has been used for a long time.

Mobile phones

Use of mobile phones can interfere with the audio system. Computer operation is not impaired but it is recommended that a distance of 30 cm be maintained between the computer and a mobile phone in use.

Central Processing Unit (CPU) Performance Disclaimer

CPU performance in your computer product may vary from specifications under the following conditions:

- Use of certain peripheral products
- Use of battery power instead of AC power
- Use of certain multimedia games or videos with special effects
- Use of standard telephone lines or low speed network connections
- Use of complex modelling software, such as high end computer aided design applications
- Use of the computer in areas with low air pressure (high altitude > 1,000 meters or > 3,280 feet above sea level)
- Use of the computer at temperatures outside the range of 5°C to 30°C (41°F to 86°F) or > 25°C (77°F) at high altitude (all temperature references are approximate).

CPU performance may also vary from specifications due to design configuration.

Under some conditions, your computer product may automatically shut down. This is a normal protective feature designed to reduce the risk of lost data or damage to the product when used outside recommended conditions. To avoid risk of lost data, always make back-up copies of data by periodically storing it on an external storage medium. For optimum performance, use your computer product only under recommended conditions. Read additional restrictions under *Environmental requirements* in Appendix A, *Specifications*. Contact TOSHIBA Technical Service and Support for more information.

CE compliance

This product and the original options are designed to observe the related EMC (Electromagnetic compatibility) and safety standards. However, TOSHIBA should not guarantee that this product still observes these EMC standards if options or cables not produced by TOSHIBA are connected or implemented. In this case the persons who have connected / implemented those options / cables have to assure that the system (PC plus options / cables) still fulfils the required standards. To avoid in general EMC problems following advice should be observed:

- Only CE marked options should be connected / implemented
- Only best shielded cables should be connected

Working environment

This product was designed to fulfil the EMC (electromagnetic compatibility) requirements to be observed for so-called "Residential, commercial and light industry environments".

TOSHIBA do not approve the use of this product in working environments other than the above mentioned "Residential, commercial and light industry environments".

For example, the following environments are not approved:

- Industrial Environments (environments with a mains voltage >230V~)
- Medical Environments
- Automotive Environments
- Aircraft Environments



If this product is supplied with a network port, please refer to the paragraph "Network connection".

Any consequences resulting from the use of this product in working environments that are not approved are not the responsibility of TOSHIBA Europe GmbH.

The consequences of the use of this product in non-approved working environments may be:

- Interference with other devices or machines in the near surrounding area
- Malfunction of, or data loss from, this product caused by disturbances generated by other devices or machines in the near surrounding area

Therefore TOSHIBA strongly recommend that the electromagnetic compatibility of this product should be suitably tested in all non-approved working environments before use. In the case of automobiles or aircraft, the manufacturer or airline respectively should be asked for permission before use of this product.

Furthermore, for general safety reasons, the use of this product in environments with explosive atmospheres is not permitted.

Network connection (class A warning)

If this product has networking capabilities and will be connected to a network, Class A radiation limits will be observed (in accordance with technical conventions). This means that if the product will be used in a domestic environment, other devices in the near surrounding may suffer interference. Consequently, please do not use this product in such environments (for example a living room), otherwise you could be held responsible for any ensuing interference.

Information on the secure use of the CD-RW

Please adhere to the following information on the use of the CD-RW to minimise the risk of unsuccessful storing process. As the storing may be unsuccessful despite your adhering to these information, for example because of a defective storing medium, you should even if the software indicates a successful storage, always check if the data has been stored successfully.

The cautions on use of a TOSHIBA A40 Series computer

Cleaning of the dust accumulated on the cooling vent of the computer.

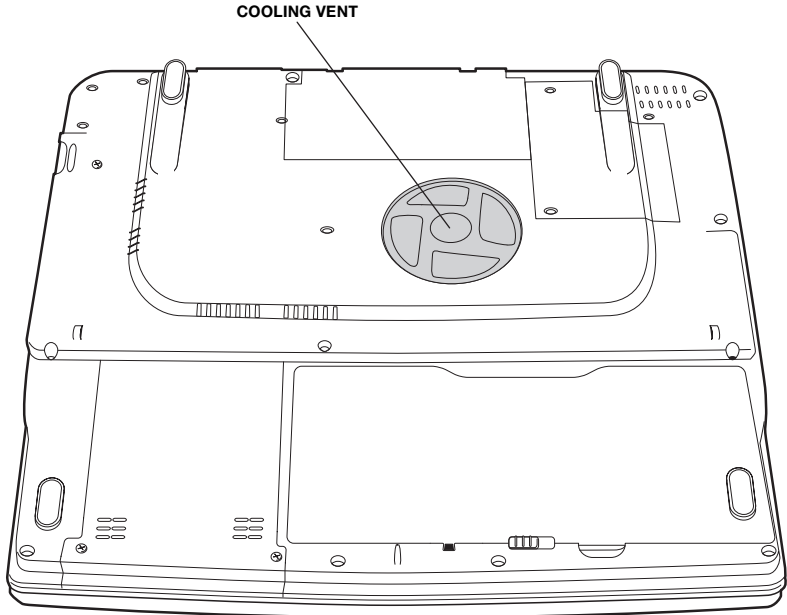

When you use your computer in a dusty area, the dusts accumulate on a cooling vent at the underside of your computer. The accumulated dusts cause insufficient heat dissipation. Clean the dusts off with vacuum cleaner.

Cooling vent at the underside of the computer.

To prevent possible overheating of the CPU, make sure the cooling fan's air intake is not blocked. The fan draws in air by creating a vacuum. If the fan is blocked, it could cause the CPU to run at a lower performance level or cause the computer to shut down. Loose items such as notebook and tissue paper, plastic wrappers, or other similar materials can block the air intake, preventing air from reaching the CPU. Do not use the computer on surfaces with objects that can be drawn in by the cooling fan.

Open the keyboard brace



Memory module and the work of the replacement of the internal modem etc. detach keyboard brace, bases such as speakers and Power buttons become baring. Never touch substrates such as bare speakers and Power buttons. It causes the breakdown when touching.

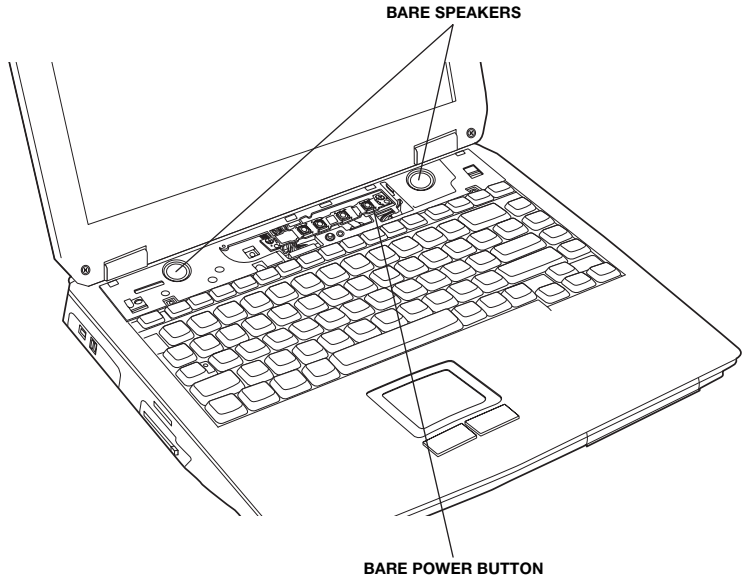

Open the keyboard brace

Table of Contents

Preface

Manual contents	xxi
Conventions	xxii
Abbreviations.....	xxii
Icons.....	xxii
Keys.....	xxii
Key operation.....	xxiii
Display.....	xxiii
Messages.....	xxiii

Chapter 1 Introduction

Equipment checklist	1-1
Hardware.....	1-1
Software.....	1-2
Documentation.....	1-2
Features	1-3
Special features	1-8
Utilities	1-11
Options	1-13

Chapter 2 The Grand Tour

Front with the display closed	2-1
Left side	2-2
Right side	2-4
Back side	2-5
Underside	2-7
Front with the display open	2-9
System indicators	2-11
Keyboard indicators	2-12
Fixed Optical media drive	2-14
Region codes for DVD drives and media.....	2-14
Writable discs	2-15
Formats	2-15
CD-RW/DVD-ROM drive	2-16
DVD-R/-RW drive	2-16
AC adaptor	2-17

Chapter 3 Getting Started

Setting up your work space	3-2
General conditions.....	3-2
Placement of the computer	3-3
Seating and posture	3-3
Lighting.....	3-4
Work habits	3-4
Connecting the AC adaptor	3-5
Opening the display	3-6
Turning on the power	3-7
Starting up for the first time	3-7
Turning off the power	3-8
Shut Down mode (Boot mode).....	3-8
Hibernation mode	3-8
Standby mode	3-10
Restarting the computer	3-12
Restoring the preinstalled software	3-12
Restoring TOSHIBA utilities and drivers	3-12

Chapter 4 Operating Basics

Using the Touch pad	4-1
Using optical media drives	4-2
Loading discs	4-3
Removing discs	4-5
Audio/Video controls	4-6
Next and Previous buttons	4-6
Play/Pause and Stop buttons.....	4-7
Controls for CD/DVD and Digital Audio	4-7
Writing to CDs with the CD RW/DVD ROM drive	4-7
Before writing or rewriting	4-8
Writing CD/DVDs on DVD-R/-RW drive	4-9
Important message.....	4-9
Disclaimer.....	4-9
Before writing or rewriting	4-10
Drag'n Drop CD+DVD.....	4-12
Data verification.....	4-12
Media care	4-13
CD/DVDs	4-13
Diskettes.....	4-13
Sound System	4-14
Volume control.....	4-14
Microphone level	4-14
SoundMAX Control Panel.....	4-14
Microphone Enhancements.....	4-15
Power management	4-15
Modem	4-16
Region selection	4-16
Properties menu	4-17
Connecting	4-18
Disconnecting.....	4-18
LAN	4-19
LAN cable types	4-19
Connecting LAN cable.....	4-19
Disconnecting LAN cable	4-20
Cleaning the computer	4-20
Moving the computer	4-21
Heat dispersal	4-21

Chapter 5 The Keyboard

Typewriter keys	5-1
F1...F12 function keys	5-2
Soft Keys: Alt Gr Key Combinations	5-2
Soft keys: Fn key combinations	5-2
Emulating keys on enhanced keyboard.....	5-3
Hot keys	5-4
Fn Sticky key	5-6
Windows special keys	5-6
Keypad overlay	5-7
Turning on the overlays	5-7
Temporarily using normal keyboard (overlay on).....	5-8
Temporarily using overlay (overlay off)	5-8
Temporarily changing modes	5-8
Generating ASCII characters	5-8

Chapter 6 Power and Power-Up Modes

Power conditions	6-1
Power indicators	6-2
Battery indicator	6-2
DC IN 15V indicator	6-3
Power indicator.....	6-3
Battery types	6-4
Battery pack	6-4
Real Time Clock battery	6-5
Care and use of the battery pack	6-5
Safety precautions.....	6-5
Charging the batteries	6-8
Monitoring battery capacity.....	6-10
Maximising battery operating time	6-10
Retaining data with power off.....	6-11
Extending battery life.....	6-11
Replacing the battery pack	6-12
Removing the battery pack	6-12
Installing the battery pack	6-14
Starting the computer by password	6-15
Power-up modes	6-15
Windows utilities.....	6-15
Hot keys	6-15
Panel power on/off	6-16
System Auto Off	6-16

Chapter 7 HW Setup and Passwords

HW Setup	7-1
Accessing HW Setup.....	7-1
HW Setup window	7-1
Supervisor password	7-10

Chapter 8 Optional Devices

PC cards.....	8-2
Inserting a PC card	8-2
Removing a PC card.....	8-3
Memory	8-4
Installing a memory module.....	8-5
Removing memory module.....	8-9
Battery pack.....	8-10
Universal AC adaptor	8-10
USB diskette drive.....	8-10
External monitor	8-10
Parallel printer	8-11
Security lock	8-12

Chapter 9 Troubleshooting

Problem solving process	9-1
Preliminary checklist.....	9-2
Analysing the problem	9-2
Hardware and system checklist	9-3
System start-up	9-4
Self test.....	9-4
Power	9-4
Password.....	9-7
Keyboard	9-7
LCD panel.....	9-10
Hard disk drive	9-11
CD-RW/DVD-ROM drive	9-11
DVD-R/-RW drive	9-13
Diskette drive.....	9-14
PC card.....	9-15
Pointing device	9-15
USB	9-17
Memory expansion	9-17
Sound system.....	9-18
External Monitor	9-18
Modem	9-19
Standby/Hibernation.....	9-20
LAN.....	9-20
Real Time Clock	9-20
Printer	9-21
If you need further assistance	9-22
Before you call.....	9-22
Where to write	9-22

Appendix A Specifications

Appendix B AC Power Cord and Connectors

Appendix C Keyboard Layouts

Appendix D Display Controller and Modes

Appendix E If your computer is stolen

Appendix F ASCII Character Codes

Appendix G Internal Modem Guide

Glossary

Index

Preface

Congratulations on your purchase of the TOSHIBA A40 Series computer. This powerful, notebook computer is designed to provide years of reliable, high-performance computing.

This manual tells how to set up and begin using your TOSHIBA A40 Series computer. It also provides detailed information on configuring your computer, basic operations and care, using optional devices and troubleshooting.

If you are a new user of computers or if you're new to portable computing, first read over the *Introduction* and *The Grand Tour* chapters to familiarise yourself with the computer's features, components and accessory devices. Then read *Getting Started* for step-by-step instructions on setting up your computer.

If you are an experienced computer user, please continue reading the preface to learn how this manual is organised, and then become acquainted with this manual by browsing through its pages. Be sure to look over the *Special features* section of the *Introduction*, to learn about features that are uncommon or unique to the computers and carefully read *HW Setup and Passwords*. If you are going to install PC cards or connect external devices such as a monitor, be sure to read Chapter 8, *Optional Devices*. Also read *Getting Started* for procedures on restoring your preinstalled software.

Manual contents

This manual is composed of nine chapters, seven appendices, a glossary, and an index.

Chapter 1, *Introduction*, is an overview of the computer's features, capabilities, and options.

Chapter 2, *The Grand Tour*, identifies the components of the computer and briefly explains how they function.

Chapter 3, *Getting Started*, provides a quick overview of how to begin operating your computer and gives tips on safety and designing your work area.

Chapter 4, *Operating Basics*, includes tips on care of the computer and on using the Touch pad, the optical media drive, optional external diskette drive, LAN and internal modem.

Chapter 5, *The Keyboard*, describes special keyboard functions including the keypad overlay and hot keys.

Chapter 6, *Power and Power-Up Modes*, gives details on the computer's power resources and battery save modes.

Chapter 7, *HW Setup and Passwords*, explains how to configure the computer using the HW Setup program and how to set passwords.

Chapter 8, *Optional Devices*, describes the optional hardware available.

Chapter 9, *Troubleshooting*, provides helpful information on how to perform some diagnostic tests, and suggests courses of action if the computer doesn't seem to be working properly.

The Appendices provide technical information about your computer.

The Glossary defines general computer terminology and includes a list of acronyms used in the text.

The Index quickly directs you to the information contained in this manual.

Conventions

This manual uses the following formats to describe, identify, and highlight terms and operating procedures.

Abbreviations

On first appearance, and whenever necessary for clarity, abbreviations are enclosed in parentheses following their definition. For example: Read Only Memory (ROM). Acronyms are also defined in the Glossary.

Icons

Icons identify ports, dials, and other parts of your computer. The indicator panel also uses icons to identify the components it is providing information on.

Keys

The keyboard keys are used in the text to describe many computer operations. A distinctive typeface identifies the key top symbols as they appear on the keyboard. For example, **Enter** identifies the Enter key.

Key operation

Some operations require you to simultaneously use two or more keys. We identify such operations by the key top symbols separated by a plus sign (+). For example, **Ctrl + C** means you must hold down **Ctrl** and at the same time press **C**. If three keys are used, hold down the first two and at the same time press the third.

Display



ABC

Names of Windows® or icons or text generated by the computer that appears on its display screen is presented in the type face you see to the left.

Text generated by the computer is usually preceded by the screen icon.

Messages

Messages are used in this manual to bring important information to your attention. Each type of message is identified as shown below.



Pay attention! A caution informs you that improper use of equipment or failure to follow instructions may cause data loss or damage your equipment.



Please read. A note is a hint or advice that helps you make best use of your equipment.

Introduction

This Chapter provides an equipment checklist, and it identifies the computer's features, options and accessories.



Some of the features described in this manual may not function properly if you use an operating system that was not preinstalled by TOSHIBA.

Equipment checklist

Carefully unpack your computer. Save the box and packing materials for future use.

Hardware

Check to make sure you have all the following items:

- TOSHIBA A40 Series Portable Personal Computer
- AC adaptor and power cord
- Modular cable

Software

- The following software is preinstalled:
 - Microsoft® Windows XP Home Edition/Professional
 - Modem driver
 - Display Drivers for Windows
 - TOSHIBA Utilities
 - Wireless LAN driver
 - Sound Driver for Windows
 - DVD Video Player
 - LAN Driver
 - TOSHIBA Power Saver
 - TOSHIBA Console
 - Online manual
 - TOSHIBA Config Free
 - TOSHIBA Touch and Launch
 - TOSHIBA PC Diagnostic Tool
- Product Recovery CD-ROM or DVD-ROM
- Tools & Utilities CD-ROM

Documentation

- *TOSHIBA A40 Series Portable Personal Computer User's Manual*
- *TOSHIBA A40 Series QuickStart*
- *Microsoft Windows XP manual*
- *Safety Instruction Manual*
- *Warranty information*

Features

The computer uses TOSHIBA's advanced Large Scale Integration (LSI), Complementary Metal-Oxide Semiconductor (CMOS) technology extensively to provide compact size, minimum weight, low power usage, and high reliability. This computer incorporates the following features and benefits:

Processor

Built-in

The computer is equipped with an Intel® processor.

- Intel® Celeron® processor, which incorporates a 128KB level 2 cache memory.
 - 2.60 GHz Intel® Celeron® processor
2.60 GHz
 - 2.70 GHz Intel® Celeron® processor
2.70 GHz
 - 2.80 GHz Intel® Celeron® processor
2.80 GHz
- Mobile Intel® Pentium® 4-M processor which incorporates a 512KB level 2 cache memory.
 - 2.66 GHz Mobile Intel® Pentium® 4 processor 2.66 GHz-M
 - 2.80 GHz Mobile Intel® Pentium® 4 processor 2.80 GHz-M
 - 3.00 GHz Mobile Intel® Pentium® 4 processor 3.00 GHz-M
 - 3.06 GHz Mobile Intel® Pentium® 4 processor 3.06 GHz-M
- Mobile Intel® Pentium® 4 processor which incorporates a 512KB level 2 cache memory.
 - Mobile Intel® Pentium® 4 processor 3.20GHz supporting Hyperthreading Technology*1

*1Hyper-Threading Technology requires a computer system with an Intel® Pentium® 4 processor supporting HT Technology and a Hyper-Threading Technology enabled chipset, BIOS and operating system.

Performance will vary depending on the specific hardware and software you use.

See <http://www.intel.com/info/hyperthreading/> for more information including details on which processors support HT Technology.

Memory

Slots	256 MB , 512 MB or 1GB memory module (PC2700, DDR) can easily be installed in the computer.
--------------	---

Video RAM	Part of system memory is used for Video RAM, of which available capacity depends on the size of system memory: <ul style="list-style-type: none">■ 256MB or more of system memory: the maximum Video RAM capacity is 64MB.
------------------	--

Power

Battery pack	The computer is powered by one rechargeable lithium-ion battery pack.
---------------------	---

RTC battery	The computer has an internal battery to back up the internal Real Time Clock (RTC) and calendar.
--------------------	--

AC adaptor	The Universal AC adaptor provides power to the system and recharges the batteries when they are low. It comes with a detachable power cord. Because it is universal, it can receive a range of AC voltage from 100 to 240 volts; however, the output current varies among different models. Using the wrong model can damage your computer. See the <i>AC adaptor</i> section in Chapter 2, <i>The Grand Tour</i> .
-------------------	--

Disks

Hard disk drive	<p>Available in four sizes.</p> <ul style="list-style-type: none"> ■ 27.94 GB (30.0 billion bytes) ■ 37.26 GB (40.0 billion bytes) ■ 55.88 GB (60.0 billion bytes)
CD-RW/DVD-ROM drive	<p>Some models are equipped with a full-size, CD-RW/DVD-ROM drive module that lets you run CD/DVDs without using an adaptor. It reads DVD-ROMs at maximum 8 speed and CD-ROMs at maximum 24 speed. It writes CD-R at up to 24 speed and CD-RW at up to 10 speed. For reading, this drive supports the same formats as the DVD-ROM drive.</p> <ul style="list-style-type: none"> ■ DVD-ROM ■ DVD-Video ■ CD-DA ■ CD-Text ■ Photo CD™ (single/multi-session) ■ CD-ROM Mode 1, Mode 2 ■ CD-ROM XA Mode 2 (Form1, Form2) ■ Enhanced CD (CD-EXTRA) ■ CD-G (Audio CD only) ■ Addressing Method 2
DVD-R/-RW drive	<p>Some models are equipped with a full-size DVD-R/-RW drive module that lets you record data to rewritable CD/DVDs as well as run either 12cm (4.72") or 8cm (3.15") CDs/12cm(4.72") DVD-ROMs at maximum 8 speed and CD-ROMs at maximum 24 speed. It writes CD-R at up to 16 speed, CD-RW at up to 10 speed, DVD-R and DVD-RW at single speed. This drive supports the same formats as the DVD-ROM drive.</p> <ul style="list-style-type: none"> ■ DVD-ROM ■ DVD-Video ■ CD-DA ■ CD-Text ■ Photo CD™ (single/multi-session) ■ DVD-Video ■ CD-ROM Mode 1, Mode 2 ■ CD-ROM XA Mode 2 (Form1, Form2) ■ Enhanced CD (CD-EXTRA) ■ CD-G (Audio CD only) ■ Addressing Method 2 ■ DVD-ROM

Display

The computer's LCD panel supports high-resolution video graphics. The screen can be set at a wide range of viewing angles for maximum comfort and readability.

Built-in	15.0"XGA/SXGA+TFT screen, 16 M colours, with the following resolution: ■ XGA, 1024 horizontal × 768 vertical pixels
Graphics controller	Graphics controller maximizes display performance. Refer to Appendix D for more information.

Keyboard

Built-in	85 keys or 86 keys, compatible with IBM enhanced keyboard, embedded numeric overlay, dedicated cursor control, and two Windows keys. See Chapter 5, <i>The Keyboard</i> , for details.
-----------------	--

Pointing device

Built-in Touch pad	A Touch pad and control buttons in the palm rest enable control of the on-screen pointer.
---------------------------	---

Ports

Parallel	Parallel printer or other parallel device (ECP compatible).
External monitor	15-pin, analog VGA port supports VESA DDC2B compatible functions.
Universal Serial Bus (USB 2.0)	The computer has four Universal Serial Bus ports that comply with the USB 2.0 standard, which enables data transfer speeds 40 times faster than the USB 1.1 standard. (The ports also support USB 1.1.)

Slots

PC card	The PC card slot accommodates one 5 mm Type II card.
----------------	--

Multimedia

Sound System	Windows Sound System compatible Sound System provides internal speakers as well as jacks for an external microphone and headphone.
Headphone jack	This jack outputs analog audio signals.
Microphone jack	A 3.5 mm mini microphone jack enables connection of a three-conductor mini jack for monaural microphone input.
Audio/Video control buttons	Audio/Video control buttons let you use the computer's optical media drive as a stand-alone audio CD player. You can also use the buttons to control the computer's DVD video player and Windows Media player when the system is on.

Communications

Modem	An internal modem provides capability for data and fax communication. It supports V.90 (V.92). The speed of data transfer and fax depends on analog telephone line conditions. It has a modem jack for connecting to a telephone line. V.92 is supported only in USA, Canada, Australia, UK, France and Germany. V.90 is available in other regions.
LAN	The computer is equipped with a LAN card that supports Ethernet LAN (10 Mbit/s, 10BASE-T) and Fast Ethernet LAN (100 Mbit/s, 100BASE-TX).

Security

Security lock slot	Connects an optional security lock to anchor the computer to a desk or other large object.
---------------------------	--

Software

Operating System	Windows XP Home Edition/Professional Edition operating system and TOSHIBA Utilities and drivers preinstalled on the hard disk. Refer to the Software section at the front of this chapter.
TOSHIBA Utilities	A number of utilities and drivers are preinstalled to make your computer more convenient to use. Refer to the Utilities section in this chapter.
Plug and Play	When you connect an external device to the computer or when you install a component, Plug and Play capability enables the system to recognize the connection and make the necessary configurations automatically.

Special features

The following features are either unique to TOSHIBA computers or are advanced features, which make the computer more convenient to use.

Hot keys	Key combinations let you quickly modify the system configuration directly from the keyboard without running a system configuration program.
Display automatic power off	This feature automatically cuts off power to the internal display when there is no keyboard input for a time specified. Power is restored when any key is pressed. You can specify the time in the Monitor Power off item of the Basic Setup tab in TOSHIBA Power Saver.
HDD automatic power off	This feature automatically cuts off power to the hard disk drive when it is not accessed for a time specified. Power is restored when the hard disk is accessed. You can specify the time in the HDD Power off item of the Basic Setup tab window in TOSHIBA Power Saver.
System automatic Standby/Hibernation	This feature automatically shuts down the system in standby mode or Hibernation mode when there is no input or hardware access for a time specified. You can specify the time and select either System Standby or System Hibernate in the System standby and System hibernation item of the Basic Setup tab in TOSHIBA Power Saver.

Keypad overlay	A ten-key pad is integrated into the keyboard. Refer to the <i>Keypad overlay</i> section in Chapter 5, <i>The Keyboard</i> , for instructions on using the keypad overlay.
Power on password	Two levels of password security are available: supervisor and user. This feature prevents unauthorized access to your computer.
Instant security	A hot key function blanks the screen and disables the computer providing quick and easy data security.
Intelligent power supply	A microprocessor in the computer's intelligent power supply detects the battery's charge and calculates the remaining battery capacity. It also protects electronic components from abnormal conditions, such as voltage overload from a universal AC adaptor. You can monitor remaining battery capacity. Use the Battery remaining item of the Power Save Modes window in TOSHIBA Power Saver.
Battery save mode	This feature lets you save battery power. You can specify the Power Save Mode in the Profile item in TOSHIBA Power Saver.
Panel power on/off	This feature turns power to the computer off when the display panel is closed and turns it back on when the panel is opened. You can specify the setting in the When I close the lid item of the Setup Action tab in TOSHIBA Power Saver.
Low battery automatic hibernation	When battery power is exhausted to the point that computer operation cannot be continued, the system automatically enters Hibernation and shuts down. You can specify the setting in Setup Action tab in TOSHIBA Power Saver.

Heat dispersal

To protect from overheating, the CPU has an internal temperature sensor. If the computer's internal temperature rises to a certain level, the cooling fan is turned on or the processing speed is lowered. Use the **Fan** item of the **Basic Setup** tab in TOSHIBA Power Saver.

Maximum Performance	Turns on fan first, then if necessary lowers CPU processing speed.
Performance	Uses a combination of fan and lowering the CPU processing speed.
Battery optimised	Lowers the CPU processing speed first, then if necessary turns on the fan.

Hibernation

This feature lets you turn off the power without exiting from your software. The contents of main memory are saved to the hard disk, when you turn on the power again, you can continue working right where you left off. Refer to the *Turning off the power* section in Chapter 3, *Getting Started*, for details.

Standby

If you have to interrupt your work, you can turn off the power without exiting from your software. Data is maintained in the computer's main memory. When you turn on the power again, you can continue working right where you left off.

Utilities

This section describes preinstalled utilities and tells how to start them. For details on operations, refer to each utility's online manual, help files or readme.txt files.

TOSHIBA Power Saver	To access this power savings management program, click the Control Panel and select the TOSHIBA Power Saver icon.
HW Setup	This program lets you customize your hardware settings according to the way you work with your computer and the peripherals you use. To start the utility, click the Windows Start button and click Control Panel. Click the Printers and other Hardware, select the TOSHIBA HW Setup icon.
DVD Video Player	The DVD Video Player is used to play DVD-Video. It has an on-screen interface and functions. Click Start, point to All Programs, point to InterVideo WinDVD 4, then click InterVideo WinDVD 4.
ConfigFree	ConfigFree is a suite of utilities to allow easy control of communication device and network connections. ConfigFree also allows you to find communication problems and create profiles for easy switching between location and communication networks. To start ConfigFree, click the Windows Start Button, point to All Programs, point to TOSHIBA, point to Networking and click ConfigFree.
Drag'n Drop CD+DVD	This easy-to-use software lets you record CD/DVDs with just a few mouse clicks. You can create CD/DVDs in several formats including audio CDs that can be played on a standard stereo CD player and data CDs to store the files and folders on your hard drive. This software can be used on a model with CD-RW/DVD-ROM drive, DVD Multi drive, DVD-R/-RW drive and DVD±RW drive.

TOSHIBA Touch Pad On/Off Utility

Pressing Fn + F9 in a windows environment enables or disables the Touch Pad function. When you press these hot keys, the current setting will change and be displayed as an icon.

TOSHIBA Touch and Launch

TOSHIBA Touch and Launch is a tool that allows you to perform various tasks easily using Touch pad. TOSHIBA Touch and Launch is useful in the following conditions.

- To open a file located on the desktop whose icon is obscured by a window.
- To open a page contained in the Internet Explorer Favourites menu.
- To display the list of currently open windows and change the active window.

Also TOSHIBA Touch and Launch provides the following functions by customizing the settings.

- To open a file stored in a predefined folder.
- To quickly launch your frequently used applications which have been registered.

PC Diagnostic Tool

TOSHIBA PC Diagnostic Tool displays the basic information on PC, and the test of built-in devices can also be performed. You can boot TOSHIBA PC Diagnostic Tool from the menu bar as follows.

Start -> All Programs -> TOSHIBA -> Utilities -> PC Diagnostic Tool

Options

You can add a number of options to make your computer even more powerful and convenient to use. The following options are available:

Memory expansion	256 MB , 512 MB or 1GB memory module (PC2700, DDR) can easily be installed in the computer.
Battery pack	An addition Battery pack can be purchased from your TOSHIBA dealer. The Battery Pack is identical to the one that came with your computer. Use it as a spare or replacement.
Universal AC adaptor	If you use your computer at more than one site frequently, it may be convenient to purchase an additional universal AC adaptor for each site so you will not have to carry the adaptor with you.
USB FDD Kit	A 3 ½" diskette drive accommodates 1.44-megabyte or 720-kilobyte diskette. It connects to a USB port. (You cannot format 720-kilobyte diskettes on Windows XP, but you can use previously formatted disks.)
Security lock	The slots is available to attach a security cable to the computer to deter theft.

Chapter 2

The Grand Tour

This Chapter identifies the various components of your computer. Become familiar with each component before you operate the computer.

Front with the display closed

The figure below shows the computer's front with its display panel in the closed position.

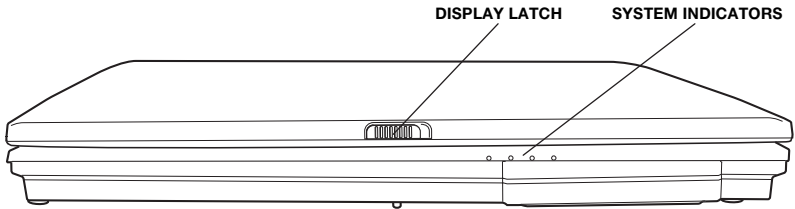

Front of the computer with display closed

Display latch	This latch secures the LCD panel in its closed position. Slide the latch to open the display.
System indicators	LEDs let you monitor the status of various computer functions. Details are given in the <i>Indicators</i> section.

Left side

The figure below shows the computer's left side.

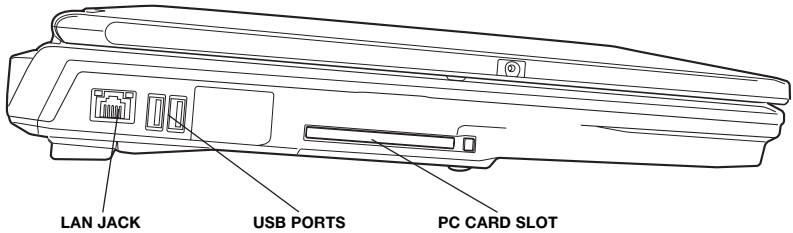

The left side of the computer

LAN active indicator (orange)	This indicator glows orange when data is being exchanged between the computer and the LAN.
Link indicator (green)	This indicator glows green when the computer is connected to a LAN and the LAN is functioning properly.
[Ether] LAN jack	This jack lets you connect to a LAN. The adaptor has built-in support for Ethernet LAN (10 megabits per second, 10BASE-T) and Fast Ethernet LAN (100 megabits per second, 100BASE-Tx). The LAN has two indicators. See Chapter 4, <i>Operating Basics</i> , for details.



Do not connect cables other than LAN, otherwise it causes a failure or damage.

Do not connect equipment which supplies electric power, otherwise it causes a failure or damage.

**Universal Serial Bus (USB 2.0) ports**

Two Universal Serial Bus ports are on the left side. The ports comply with the USB 2.0 standard, which enables data transfer speed 40 times faster than the USB 1.1 standard. (The ports also support USB 1.1.) Also two ports are on the back side.



Keep foreign objects out of the USB connectors. A pin or similar object can damage the computer's circuitry.

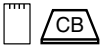

Operation of all functions of all USB devices has not been confirmed. Some functions might not execute properly.

**PC card slot**

A PC card slot can accommodate one 5 mm Type II card. You can install any industry standard PC card such as a SCSI adaptor, Ethernet adaptor or flash memory card.



Keep foreign objects out of the PC card slot. A pin or similar object can damage the computer's circuitry.

Right side

The figure below shows the computer's right side.

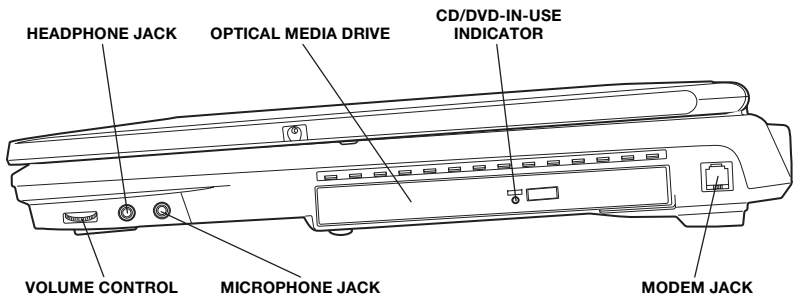

The right side of the computer

Fixed Optical Media Drive

The computer is configured with a full-size optical media drive module that lets you run either 12 cm (4.72") or 8 cm (3.15") disks without using an adaptor. Refer to the *Fixed Optical media drive* section in this Chapter for technical specifications on each drive and to Chapter 4, *Operating Basics*, for information on using the drive and caring for disks.

The following drives are available:

- CD-RW/DVD-ROM drive
- DVD-R/-RW drive



Modem jack

The modem jack lets you use a modular cable to connect the modem directly to a telephone line.



In case of a lightning storm, unplug the modem cable from the telephone jack.

Do not connect the modem to a digital telephone line. A digital line will damage the modem.



	Volume control	Use this dial to adjust the volume of the stereo speakers or the stereo headphones.
	Microphone jack	A standard 3.5 mm mini microphone jack enables connection of a monaural microphone or other device for audio input. When you connect an external microphone, the internal microphone is automatically disabled.
	Headphone jack	A standard 3.5 mm mini headphone jack enables connection of a stereo headphone (16 ohm minimum) or other device for audio output. When you connect headphones, the internal speakers are automatically disabled.
CD/DVD-in-use indicator	This indicator glows green when the computer is accessing a diskette in the diskette drive or a disk in the optical media drive.	

Back side

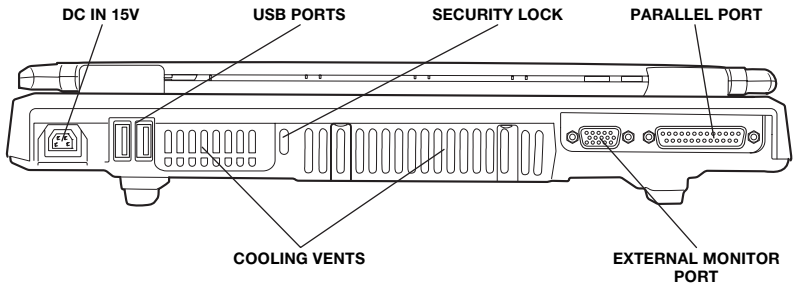
The figure below shows the computer's back side.



The back side of the computer

	Parallel port	This Centronics-compatible, 25-pin parallel port that is used to connect a parallel printer or other parallel device. This port supports Extended Capabilities Port (ECP) standard.
	External monitor port	This 15-pin port lets you connect an external monitor.



Universal Serial Bus (USB 2.0) ports

Two Universal Serial Bus ports are on the back side. The port comply with the USB 2.0 standard, which enables data transfer speed 40 times faster than the USB 1.1 standard. (The ports also support USB 1.1.) Also two ports are on the left side.



Security lock

A security cable attaches to this slot. The optional security cable anchors your computer to a desk or other large object to deter theft.



Keep foreign objects out of the USB connectors. A pin or similar object can damage the computer's circuitry.

The Security Lock Slot is between the Cooling Vents. After using this computer, the Security Lock Slot is hot because of the exhaust heat from the Cooling Vents. There is a possibility of getting burnt when the Security Lock Slot is touched at this time. Therefore, be careful enough work after it is confirmed that heat is cold enough after the computer is used.



Operation of all functions of all USB devices has not been confirmed. Some functions might not execute properly.

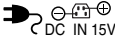

DC IN 15V

The AC adaptor connects to this socket. Use only the model of AC adaptor that comes with the computer. Using the wrong adaptor can damage your computer.

Cooling vents

These vents provide an outlet for air pulled through the computer by the fan.





Be careful not to block the cooling vents. Also be careful to keep foreign objects out of them. A pin or similar object can damage the computer's circuitry.

Underside

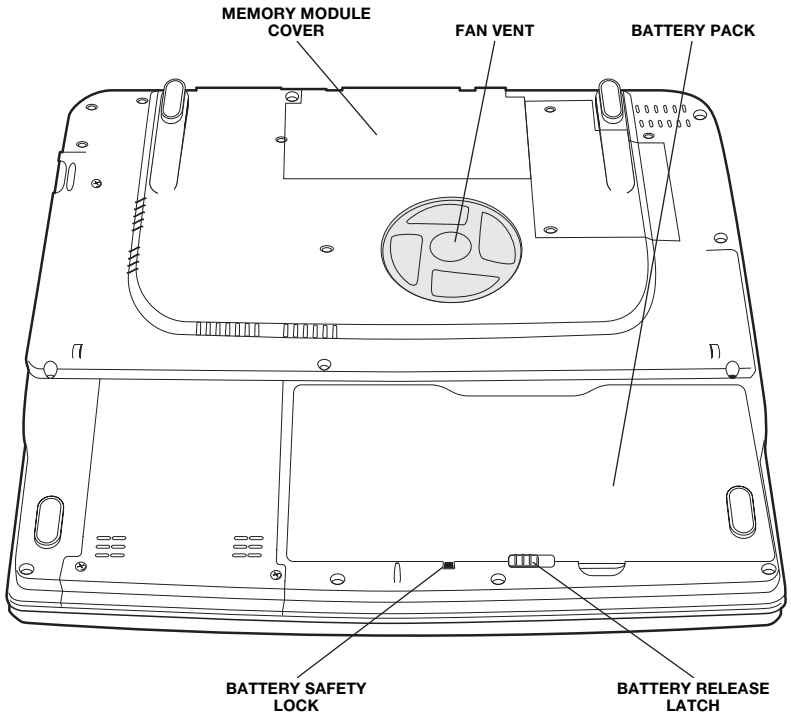
The figure below shows the underside of the computer. Make sure the display is closed before turning over your computer.



The underside of the computer

	Battery release latch	Slide this latch to release the battery pack for removal. For detailed information on removing the battery packs, refer to Chapter 6, <i>Power and Power-Up Modes</i> .
	Battery safety lock	Switch this safety lock to make the battery release latch slide freely or locked. For detailed information, refer to Chapter 6, <i>Power and Power-Up Modes</i> .
	Battery pack	The battery pack powers the computer when the AC adaptor is not connected. For detailed information on the battery pack, refer to Chapter 6, <i>Power and Power-Up Modes</i> .
	Memory module cover	This cover protects two memory module sockets. One or two modules are preinstalled. Refer to the Memory expansion section in Chapter 8, <i>Optional Devices</i> .
	Fan vent	Provides air flow for the fan.

Front with the display open

The figure below shows the front of the computer with the display open. To open the display, slide the display latch on the front of the display to the right of the computer and lift up. Position the display at a comfortable viewing angle.

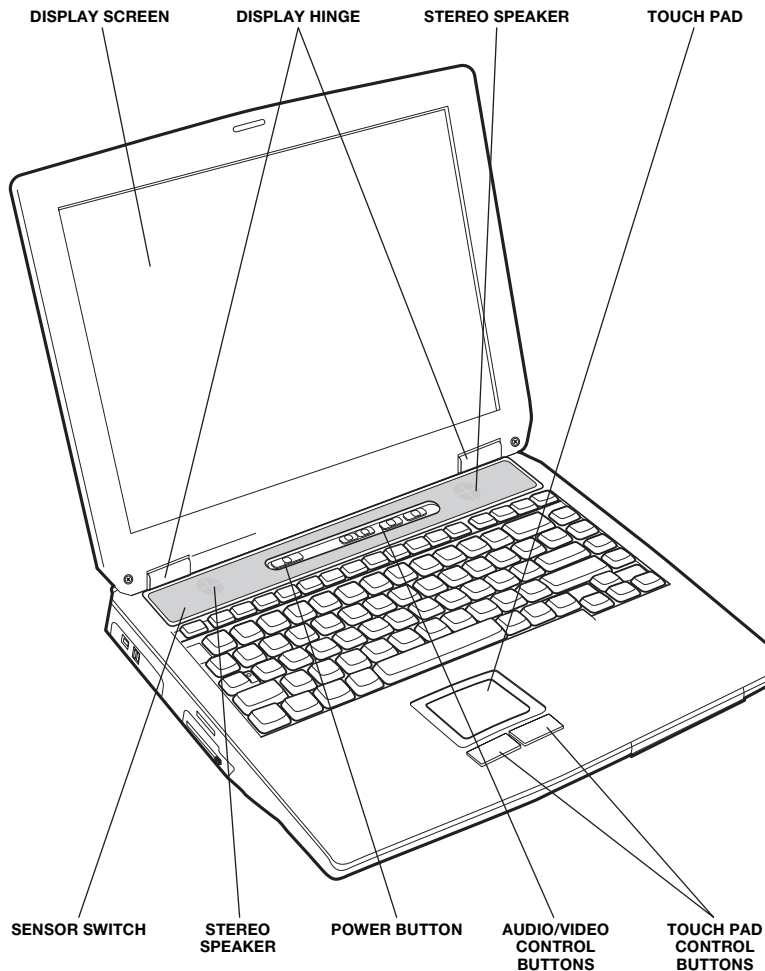

The front with the display open

Display hinge

The display hinge holds the display screen at easy-to-view angles.

Display screen	<p>The LCD displays high-contrast text and graphics. The computer's LCD consists of up to 1024 x 768 pixels. The computer has a Thin-Film Transistor (TFT) display. Refer to Appendix D.</p> <p>When the computer operates on power through the AC adaptor, the display screen's image will be somewhat brighter than when it operates on battery power. The lower brightness level is intended to save battery power.</p>
Stereo speakers	<p>The speakers emit sound generated by your software as well as audio alarms, such as low battery condition, generated by the system.</p>
Audio/Video control buttons	<p>◀◀ Previous button: Plays the previous track/chapter/data.</p> <p>▶/■ Play/pause button: Begins or pauses play.</p> <p>■ Stop button: Halts play.</p> <p>▶▶ Next button: Plays the next track/chapter/data.</p> <p>Refer to Chapter 4, <i>Operating Basics</i>.</p> <p>Audio/Video control buttons are provided with some models.</p>



If Random is selected in TOSHIBA Media Player, selecting Next or Previous advances to a random selection.



Power button	<p>Press the power button to turn the computer's power on and off.</p>
Touch pad	<p>A Touch pad located slightly in the left from the centre of the palm rest is used to control the on-screen pointer. Refer to the <i>Using the Touch pad</i> section in Chapter 4, <i>Operating Basics</i>.</p>
Touch pad control buttons	<p>Control buttons close to the Touch pad let you select menu items or manipulate text and graphics designated by the on-screen pointer.</p>
Sensor switch	<p>This switch shuts down the computer when you close the cover and the panel power on/off feature is enabled.</p>

System indicators



DC IN 15V



POWER



BATTERY



BUILT-IN HDD

System indicators

**DC IN 15V**

The **DC IN 15V** indicator glows green when DC power is supplied from the AC power adaptor. If the adaptor's output voltage is abnormal or if the power supply malfunctions, this indicator flashes orange.

**Power**

The **Power** indicator glows green when the computer is on. If you select **Standby** from **Shut Down Windows**, this indicator flashes orange (one second on, two seconds off) while the computer shuts down.

**Battery**

The **Battery** indicator shows the condition of the battery's charge: Green indicates full charge, orange indicates battery charging and flashing orange indicates a low battery charge. Refer to Chapter 6, *Power and Power-Up Modes*.

**Built-in HDD**

The **Built-in HDD** indicator glows green when the computer is accessing the hard disk.

Keyboard indicators

The figures below show the positions of the keypad overlay indicators and the CapsLock indicator.

When the F10 key indicator glows the keypad overlay lets you control the cursor. When the F11 key indicator glows the keypad overlay lets you enter numbers.

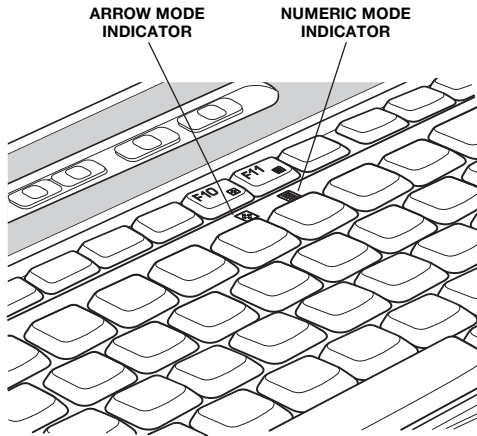

Keypad overlay indicators



Arrow mode

When the **Arrow mode** indicator lights green, you can use the keypad overlay (grey labelled keys) as cursor keys. Refer to the *Keypad overlay* section in Chapter 5, *The Keyboard*.



Numeric mode

You can use the keypad overlay (grey labelled keys) for numeric input when the **Numeric mode** indicator lights green. Refer to the *Keypad overlay* section in Chapter 5, *The Keyboard*.

When the CapsLock indicator glows the keyboard is in all-caps mode.

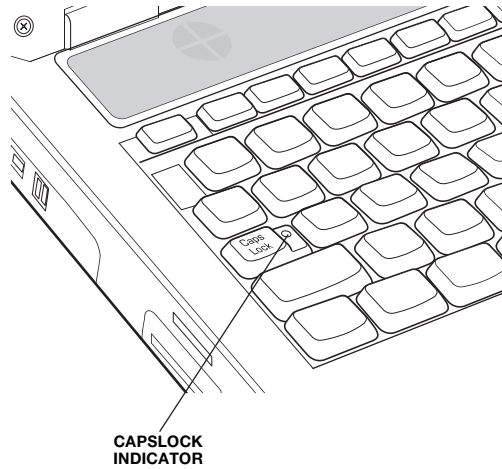

CapsLock indicator

Caps Lock

This indicator glows green when the alphabet keys are locked in uppercase.

Fixed Optical media drive

One of the following optical media drives is installed in the computer: CD-RW/DVD-ROM drive, DVD Multi drive, DVD-ROM drive, DVD-R/-RW drive, DVD±RW drive. An ATAPI interface controller is used for CD/DVD-ROM operation. When the computer is accessing a CD/DVD, an indicator on the drive glows.

Region codes for DVD drives and media

CD-RW/DVD-ROM, DVD Multi, DVD-ROM, DVD-R/-RW, DVD±RW drive and media are manufactured according to the specifications of six marketing regions. When you purchase DVD-Video, make sure it matches your drive, otherwise it will not play properly.

Code	Region
1	Canada, United States
2	Japan, Europe, South Africa, Middle East
3	Southeast Asia, East Asia
4	Australia, New Zealand, Pacific Islands, Central America, South America, Caribbean
5	Russia, Indian Subcontinent, Africa, North Korea, Mongolia
6	China

Writable discs

This section describes the types of writable CD/DVD discs. Check the specifications for your drive to for the type of discs it can write. Use Drag'n Drop CD+DVD to write compact discs. Refer to Chapter 4, *Operating Basics*.

CDs

- CD-R discs can be written only once. The recorded data cannot be erased or changed.
- CD-RW discs can be recorded more than once. Use either 1, 2, or 4 multi speed CD-RW discs or high-speed 4- to 10-speed discs.
- The write speed of the ultra-speed CD-RW discs (Ultra-speed is CD-RW/DVD-ROM drive only) is maximum 24-speed.

DVDs

- DVD-R discs can be written only once. The recorded data cannot be erased or changed.
- DVD±R, DVD+RW and DVD-RAM discs can be recorded more than once.

Formats

The drives support the following formats:

- | | |
|---|--------------------------|
| ■ DVD-ROM | ■ DVD -Video |
| ■ CD-DA | ■ CD-Text |
| ■ Photo CDTM (single/
multi-session) | ■ CD-ROM Mode 1, Mode 2 |
| ■ CD-ROM XA Mode 2
(Form1, Form2) | ■ Enhanced CD (CD-EXTRA) |
| ■ CD-G (Audio CD only) | ■ Addressing Method 2 |

CD-RW/DVD-ROM drive

The full-size CD-RW/DVD-ROM drive module lets you record data to rewritable CDs as well as run either 12 cm (4.72") or 8 cm (3.15") CD/DVDs without using an adaptor.



The read speed is slower at the centre of a disc and faster at the outer edge.

DVD read	8 speed (maximum)
CD read	24 speed (maximum)
CD-R write	24 speed (maximum)
CD-RW write	10 speed (maximum, high-speed media)

DVD-R/-RW drive

The full-size DVD-R/-RW drive module lets you record data to rewritable CD/DVDs as well as run either 12 cm (4.72") or 8 cm (3.15") CD/DVDs without using an adaptor.



The read speed is slower at the centre of a disc and faster at the outer edge.

DVD read	8 speed (maximum)
DVD-R write	2 speed
DVD-RW write	1 speed
CD read	24 speed (maximum)
CD-R write	16 speed (maximum)
CD-RW write	10 speed (maximum)

AC adaptor

The AC adaptor converts AC power to DC power and reduces the voltage supplied to the computer. It can automatically adjust to any voltage from 100 to 240 volts and to a frequency of either 50 or 60 hertz, enabling you to use the computer in almost any country/region.

To recharge the battery, simply connect the AC adaptor to a power source and the computer. See Chapter 6, *Power and Power-Up Modes* for details.

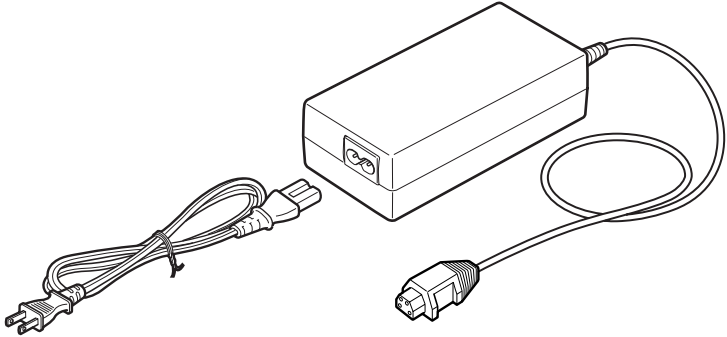

The AC adaptor



Use only the AC adaptor that came with the computer or an equivalent optional adaptor. Use of the wrong adaptor could damage your computer. TOSHIBA assumes no liability for any damage in such case.

Use only the AC adaptor supplied as an accessory. Other AC adaptors have different voltage and terminal polarities and use of them may produce heat and smoke or even result in fire or rupture.

Getting Started

This Chapter provides basic information to get you started using your computer. It covers the following topics:

- Setting up your work space — for your health and safety



Be sure also to read the Safety Instruction Manual. This guide, which is included with the computer, explains product liability.

- Connecting the AC adaptor
- Opening the display
- Turning on the power
- Starting up for the first time
- Turning off the power
- Restarting the computer
- Restoring the preinstalled software

If you are a new user, follow the steps in each section of this Chapter as you prepare to operate your computer.



All users should be sure to carefully read the section Starting up for the first time, which describe actions to take when you turn on the power for the first time.

Setting up your work space

Establishing a comfortable work site is important for you and your computer. A poor work environment or stressful work habits can result in discomfort or serious injury from repetitive strain to your hands, wrists or other joints. Proper ambient conditions should also be maintained for the computer's operation. This section discusses the following topics:

- General conditions
- Placement of the computer
- Seating and posture
- Lighting
- Work habits

General conditions

In general, if you are comfortable, so is your computer, but read the following to make sure your work site provides a proper environment.

- Make sure there is adequate space around the computer for proper ventilation.
- Make sure the AC power cord connects to an outlet that is close to the computer and easily accessible.
- The temperature should be 5 C to 35 C (41 F to 95 F) and the relative humidity should be 20 to 80 percent.
- Avoid areas where rapid or extreme changes in temperature or humidity may occur.
- Keep the computer free of dust, moisture, and exposure to direct sunlight.
- Keep the computer away from heat sources, such as electric heaters.
- Do not use the computer near liquids or corrosive chemicals.
- Do not place the computer near objects that create strong magnetic fields (e.g., stereo speakers).
- Some computers in the computer, including data storage media, can be damaged by magnets. Do not place the computer near magnetic objects or bring magnetic objects close to the computer. Be careful of objects, such as stereo speakers, that produce strong magnetic fields during operation. Also, be careful with metal objects, such as bracelets, which can be inadvertently magnetized.
- Do not operate the computer in close proximity to a mobile phone.
- Leave ample ventilation room for the fan. Do not block the vents.

Placement of the computer

Position the computer and peripheral devices to provide comfort and safety.

- Set the computer on a flat surface at a comfortable height and distance. The display should be no higher than eye level to avoid eye strain.
- Place the computer so that it is directly in front of you when you work and make sure you have adequate space to easily operate other devices.
- Allow adequate space behind the computer to let you freely adjust the display. The display should be angled to reduce glare and maximize visibility.
- If you use a paper holder, set it at about the same height and distance as the computer.

Seating and posture

The height of your chair in relation to the computer and keyboard as well as the support it gives your body are primary factors in reducing work strain. Refer to the following tips and to the figure below.

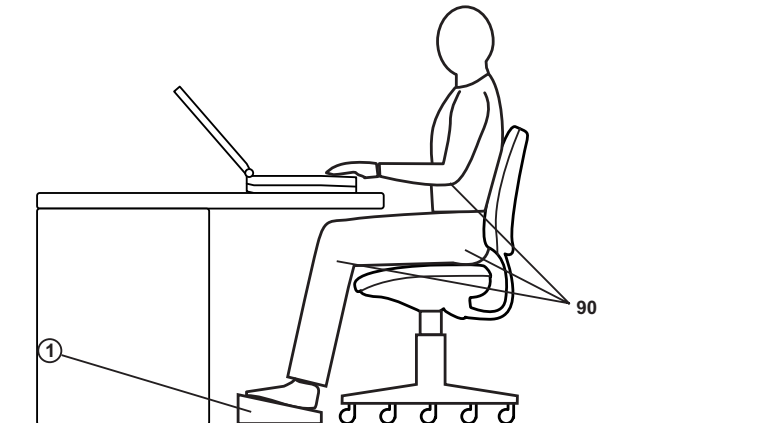

Posture and positioning of the computer

- Place your chair so that the keyboard is at or slightly below the level of your elbow. You should be able to type comfortably with your shoulders relaxed.
- Your knees should be slightly higher than your hips. If necessary, use a foot rest to raise the level of your knees to ease pressure on the back of your thighs.
- Adjust the back of your chair so it supports the lower curve of your spine.
- Sit straight so that your knees, hips and elbows form approximately 90 degree angles when you work. Do not slump forward or lean back too far.

Lighting

Proper lighting can improve legibility of the display and reduce eye strain.

- Position the computer so that sunlight or bright indoor lighting does not reflect off the screen. Use tinted windows, shades or other screen to eliminate sun glare.
- Avoid placing the computer in front of bright light that could shine directly in your eyes.
- If possible, use soft, indirect lighting in your computer work area. Use a lamp to illuminate your documents or desk, but be sure to position the lamp so that it does not reflect off the display or shine in your eyes.

Work habits

A key to avoiding discomfort or injury from repetitive strain is to vary your activities. If possible, schedule a variety of tasks into your work day. If you must spend long periods at the computer, finding ways to break up the routine can reduce stress and improve your efficiency.

- Sit in a relaxed posture. Good positioning of your chair and equipment as described earlier can reduce tension in your shoulders or neck and ease back strain.
- Vary your posture frequently.
- Occasionally stand up and stretch or exercise briefly.
- Exercise and stretch your wrists and hands a number of times during the day.
- Frequently, look away from the computer and focus your eyes on a distant object for several seconds, for example 30 seconds every 15 minutes.
- Take frequent short breaks instead of one or two long breaks, for example, two or three minutes every half hour.
- Have your eyes examined regularly and visit a doctor promptly, if you suspect you might be suffering from a repetitive strain injury.

A number of books are available on ergonomics and repetitive strain injury or repetitive stress syndrome. For more information on these topics or for pointers on exercises for such stress points as hands and wrists, please check with your library or book vendor. Also refer to the computer's *Safety Instruction Manual*.

Connecting the AC adaptor

Attach the AC adaptor when you need to charge the battery or you want to operate from AC power. It is also the fastest way to get started, because the battery pack will need to be charged before you can operate from battery power.

The AC adaptor can be connected to any power source supplying from 100 to 240 volts and 50 or 60 hertz. For details on using the AC adaptor to charge the battery pack, refer to Chapter 6, *Power and Power-Up Modes*.



Use only the AC adaptor supplied as an accessory. Other AC adaptors have different voltage and terminal polarities and use of them may produce heat and smoke or even result in fire or rupture.



Use only the AC adaptor supplied with your computer or an equivalent adaptor that is compatible. Use of any incompatible adaptor could damage your computer. TOSHIBA assumes no liability for any damage caused by use of an incompatible adaptor.

When you connect the AC adaptor to the computer, always follow the steps in the exact order as described in the User's Manual. Connecting the power cable to a live electrical outlet should be the last step otherwise the adaptor DC output plug could hold an electrical charge and cause an electrical shock or minor bodily injury when touched. As a general safety precaution, avoid touching any metal parts.

1. Connect the power cord to the AC adaptor.

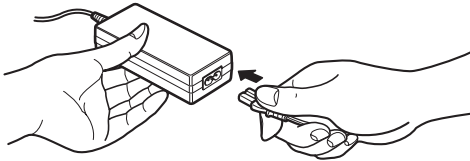

Connecting the power cord to the AC adaptor

2. Connect the AC adaptor's DC output plug to the **DC IN 15V** input port on the back of the computer.

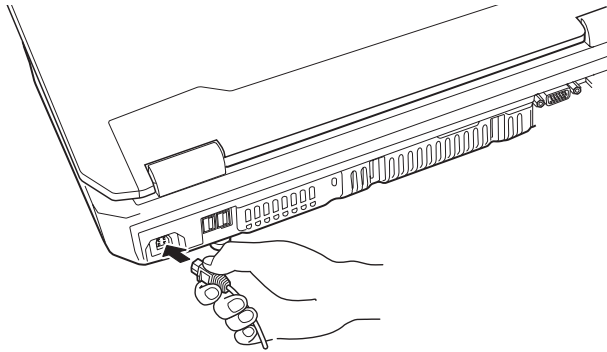

Connecting the adaptor to the computer

3. Plug the power cord into a live wall outlet. The **Battery** and **DC IN 15V** indicators on the front of the computer should glow.

Opening the display

The display panel can be rotated in a wide range of angles for optimal viewing.

1. Slide the display latch on the front of the computer to the right to unlatch the display panel.
2. Lift the display panel up and adjust it to the best viewing angle for you.



Use reasonable care when opening and closing the display panel. Opening it vigorously or slamming it shut could damage the computer.



When you open the display, hold it with both hands and lift up slowly.

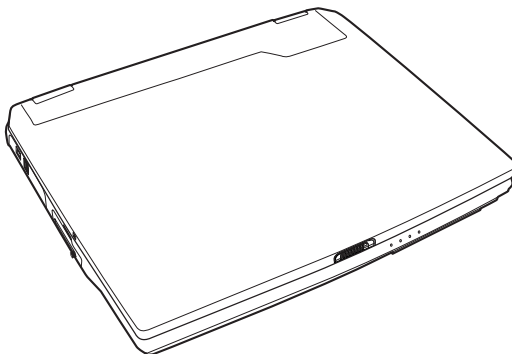

Opening the display panel

Turning on the power

This section describes how to turn on the power.



*After you turn on the power for the first time, do not turn it off until you have set up the operating system. Refer to the section *Starting up for the first time* in this chapter.*

1. If the external diskette drive is connected, make sure it is empty. If a diskette is in the drive, press the eject button and remove the diskette.
2. Open the display.
3. Press and hold the computer's power button for two or three seconds.

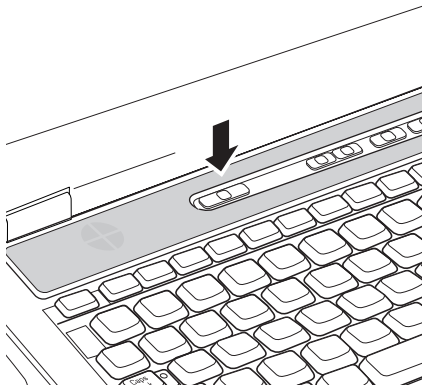

Turning on the power

Starting up for the first time

When you first turn on the power, the computer's initial screen is the Microsoft Windows XP Startup Screen Logo. Follow the on-screen directions for each screen. During setup, you can click the **Back** button to return to the previous screen.

Be sure to read the **Windows End User License Agreement** display carefully.



Be sure to read the License Agreement carefully.

Turning off the power

The power can be turned off in one of the following modes: Shut down (Boot), Hibernation or Standby mode.

Shut Down mode (Boot mode)

When you turn off the power in Shut Down mode no data is saved and the computer will boot to the operating system's main screen.

1. If you have entered data, save it to the hard disk or to a diskette.
2. Make sure all disk (disc) activity has stopped, then remove the CD/DVDs or diskette.



*Make sure the **Built-in HDD** and **CD/DVD-in-use** indicators are off. If you turn off the power while a disk (disc) is being accessed, you can lose data or damage the disk (disc).*

3. Click start then click **Turn Off Computer**. From the **Turn Off Computer** menu select **Turn Off**.
4. Turn off the power to any peripheral devices.



Do not turn the computer or devices back on immediately. Wait a moment to let all capacitors fully discharge.

Hibernation mode

The hibernation feature saves the contents of memory to the hard disk when the computer is turned off. The next time the computer is turned on, the previous state is restored. The hibernation feature does not save the status of peripheral devices.



Save your data. While entering hibernation mode, the computer saves the contents of memory to the HDD. However, for safety sake, it is best to save your data manually.

*Data will be lost if you remove the battery or disconnect the AC adaptor before the save is completed. Wait for the **Built-IN HDD** indicator to go out.*

Do not install or remove a memory module while the computer is in hibernation mode. Data will be lost.

Benefits of hibernation

The hibernation feature provides the following benefits:

- Saves data to the hard disk when the computer automatically shuts down because of a low battery.



For the computer to shut down in hibernation mode, the hibernation feature must be enabled in two places : the hibernate tab in Power Options and Setup Action tab in TOSHIBA Power Saver. Otherwise, the computer will shut down in Standby mode. If battery power becomes depleted, data saved in Standby will be lost.

- You can return to your previous working environment immediately when you turn on the computer.
- Saves power by shutting down the system when the computer receives no input or hardware access for the duration set by the System hibernate feature.
- You can use the panel power off feature.

Starting Hibernation



*You can also enable Hibernation by pressing **Fn + F4**. See Chapter 5, The Keyboard, for details.*

To enter Hibernation mode, follow the steps below.

1. Click **Start**.
2. Select **Turn Off Computer**.
3. Open the **Turn Off Computer** dialog box. **Hibernate** is not displayed.
4. Press the **Shift** key. The **Standby** item will change to **Hibernate**.
5. Select **Hibernate**.

Automatic Hibernation

The computer will enter Hibernate mode automatically when you press the power button or close the lid. First, however, make the appropriate settings according to the steps below.

1. Open the **Control Panel**.
2. Open **Performance and Maintenance** and open **Power Options**.
3. Select the **Hibernate** window; in **Power Option** property select the **Enable Hibernation** check box and click the **Apply** button.
4. Open **TOSHIBA Power Saver**.
5. Select the **Setup Action** window.
6. Enable the desired Hibernation settings for **When I press the power button** and **When I close the lid**.
7. Click the **OK** button.

Data save in hibernation mode

When you turn off the power in hibernation mode, the computer takes a moment to save current memory data to the hard disk. During this time, the **Built-IN HDD** indicator will light.

After you turn off the computer and memory is saved to the hard disk, turn off the power to any peripheral devices.



Do not turn the computer or devices back on immediately. Wait a moment to let all capacitors fully discharge.

Standby mode

If you have to interrupt your work, you can turn off the power without exiting from your software. Data is maintained in the computer's main memory. When you turn on the power again, you can continue working right where you left off.



When the AC adaptor is connected, the computer will go into Standby mode according to the settings in the TOSHIBA Power Saver utility.

To restore operation from Standby mode, press the power button or press any key. The latter action works only if Wake-up on Keyboard is enabled in HW Setup.

If the computer automatically enters Standby mode while a network application is active, the application might not be restored when the computer wakes up from Standby.

To prevent the computer from automatically entering Standby mode, disable Standby in TOSHIBA Power Saver. That action, however, will nullify the computer's Energy Star compliance.



Before entering Standby mode, be sure to save your data.

Do not install or remove a memory module while the computer is in standby mode. The computer or the module could be damaged.

Do not remove the battery pack while the computer is in standby mode (unless the computer is connected to an AC power source). Data in memory will be lost.

If you carry the computer on board an aircraft or into a hospital, be sure to shut down the computer in hibernation mode or in shutdown mode to avoid radio signal interference.

Benefits of standby

The standby feature provides the following benefits:

- Restores the previous working environment more rapidly than does hibernation.
- Saves power by shutting down the system when the computer receives no input or hardware access for the duration set by the System Standby feature.
- You can use the panel power off feature.

Executing standby



*You can also enable Standby by pressing **Fn + F3**. See Chapter 5, The Keyboard, for details.*

You can enter standby mode in one of three ways:

1. Click **start**, click **Turn Off Computer** and click **Standby**.
2. Close the display panel. This feature must be enabled. Refer to the *Setup Action* tab in *Power Saver Utility* described in the Control Panel. Open **Performance and Maintenance** and open **TOSHIBA Power Saver**.
3. Press the power button. This feature must be enabled. Refer to the *Setup Action* tab in *Power Saver Utility* described in the Control Panel. Open **Performance and Maintenance** and open **TOSHIBA Power Saver**.

When you turn the power back on, you can continue where you left when you shut down the computer.



When the computer is shut down in standby mode, the power indicator flashes orange.

If you are operating the computer on battery power, you can lengthen the operating time by shutting down in hibernation mode. Standby mode consumes more power.

Standby limitations

Standby will not function under the following conditions:

- Power is turned back on immediately after shutting down.
- Memory circuits are exposed to static electricity or electrical noise.

Restarting the computer

Certain conditions require that you reset the system. For example, if:

- You change certain computer settings.
- An error occurs and the computer does not respond to your keyboard commands.

There are three ways to reset the computer system:

1. Click **start** then click **Turn off computer**. From the **Turn off computer** menu select **Restart**.
2. Press **Ctrl + Alt + Del** to display the **Windows Task Manager**, and then select **Shutdown** and **Restart**.
3. Select **Restart** from the **Turn Off Computer** window in the **start** menu.
4. Press the power button and hold it down for five seconds. Wait 10 to 15 seconds, and then turn the power on again by pressing the power button.

Restoring the preinstalled software

If preinstalled files are damaged, use the Product Recovery disk or the TOSHIBA Tools & Utilities CD-ROM to restore them. To restore the operating system and all preinstalled software, follow the steps below.



When you reinstall the Windows operating system, the hard disk will be reformatted and all data will be lost. Make sure you have a backup copy of your data, before you perform a complete system recovery.

1. Load the Product Recovery disk in the optical media drive and turn off the computer's power.
2. Hold down the **F12** key and turn on the power. When the TOSHIBA logo appears, release the **F12** key.
3. Use the left or right cursor key to select the **CD/DVD-ROM Drive** in the display menu. For details, refer to the *Boot priority* section in Chapter 7, *HW Setup and Passwords*.
4. Follow the on-screen instructions.
5. If your computer came with additional software installed, this software cannot be recovered from the Product Recovery disk. Re-install these applications (e.g. Works Suite, DVD Player, Games, etc) separately from other media.

Restoring TOSHIBA utilities and drivers

1. If Windows is working properly, individual drivers or applications can be separately restored. Use the Tools & Utilities CD-ROM according to instructions in the booklet contained in the CD box to reinstall TOSHIBA utilities and drivers.

Operating Basics

This Chapter gives information on basic operations including using the Touch pad, optical media drives, audio/video controls, Sound System, the internal modem and LAN. It also provides tips on caring for your computer and on heat dispersal.

Using the Touch pad

To use the Touch pad, simply touch and move your finger tip across it in the direction you want the on-screen pointer to go.

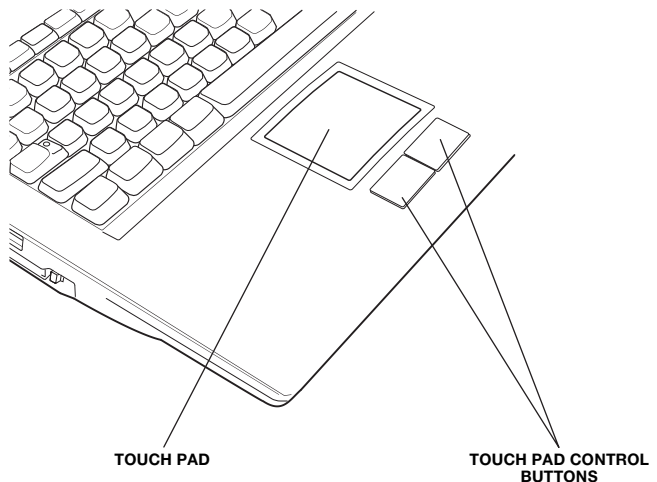

Touch pad and Touch pad control buttons

Two buttons below the keyboard are used like the buttons on a mouse pointer. Press the left button to select a menu item or to manipulate text or graphics designated by the pointer. Press the right button to display a menu or other function depending on the software you are using.



Do not press on the Touch pad too hard or press a sharp object such as a ball point pen against the Touch pad. The Touch pad could be damaged.

For some functions, you can tap the Touch pad instead of pressing a control button.

Click	Tap the Touch pad once
Double-click	Tap the Touch pad twice
Drag and drop	<ol style="list-style-type: none"> 1. Hold down the left control button and move the cursor to drag the item you want to move. 2. Lift your finger to drop the item where you want it.
Scroll	<p>Vertical: Move your finger up or down the right edge of the Touch pad.</p> <p>Horizontal: Move your finger left or right along the bottom edge of the Touch pad.</p>

Using optical media drives

The illustrations in this section might differ slightly from your drive, but operation is the same for all optical media drives. The full-size drive provides high-performance execution of CD/DVD-ROM-based programs. You can run either 12 cm (4.72") or 8 cm (3.15") CD/DVDs without an adaptor. An ATAPI interface controller is used for CD/DVD-ROM operation. When the computer is accessing a CD/DVD, an indicator on the drive glows.



Use the WinDVD 4 application to view DVD-Video discs.

If you have a CD-RW/DVD-ROM drive, refer also to the *Writing CDs on CD-RW/DVD-ROM drive* section for precautions on writing to CDs.

If you have a DVD Multi drive, refer also to the *Writing CD/DVDs on DVD Multi drive* section for precautions on writing to CDs.

If you have a DVD-R/-RW, refer also to the *Writing CD/DVDs on DVD-R/-RW drive* section for precautions on writing to CDs.

If you have a DVD±RW drive, refer also to the *Writing CD/DVDs on DVD±RW drive* section for precautions on writing to CDs.

Loading discs

To load CD/DVDs, follow the steps below and refer to the figures below.

1. a. When the power is on, press the eject button to open the drawer slightly.

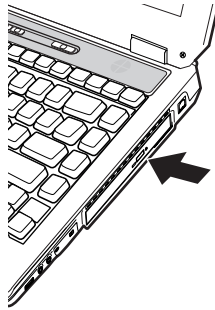

Pressing the eject button

- b. Pressing the eject button will not open the drawer when the drive's power is off. If the power is off, you can open the drawer by inserting a slender object (about 15 mm) such as a straightened paper clip into the eject hole just to the left of the eject button.

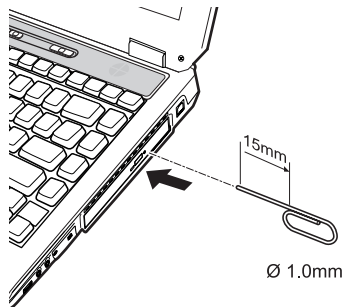

Manual release with the eject hole

- Pinch the drawer gently and pull until it is fully opened.

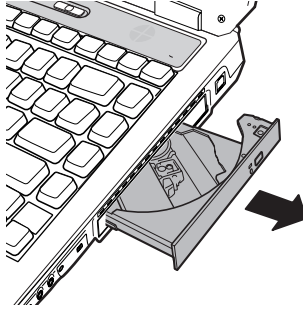

Pulling the drawer open

- Lay the CD/DVD, label side up, in the drawer.



Inserting a CD/DVD



When the drawer is fully opened, the edge of the computer will extend slightly over the CD/DVD tray. Therefore, you will need to turn the CD/DVD at an angle when you place it in the tray. After seating the CD/DVD, however, make sure it lies flat, as shown in the figure below.



Do not touch the laser lens. Doing so could cause misalignment. Do not keep foreign matter from entering the drive. Check the back edge of the tray to make sure it carries no debris before closing the drive.

4. Press gently at the centre of the CD/DVD until you feel it click into place. The CD/DVD should lie below the top of the spindle, flush with the spindle base.
5. Push the centre of the drawer to close it. Press gently until it locks into place.



If the CD/DVD is not seated properly when the drawer is closed, the CD/DVD might be damaged. Also, the drawer might not open fully when you press the eject button.

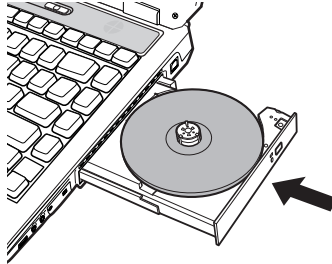

Closing the CD/DVD drawer

Removing discs

To remove the CD/DVD, follow the steps below and refer to the figure below.



*Do not press the eject button while the computer is accessing the optical media drive. Wait for the **CD/DVD-in-use** indicator to go out before you open the drawer. Also, if the CD/DVD is spinning when you open the drawer, wait for it to stop before you remove it.*

1. To pop the drawer partially open, press the eject button. Gently pull the drawer out until it is fully opened.



When the drawer pops open slightly, wait a moment to make sure the CD/DVD has stopped spinning before pulling the drawer fully open.

Turn off the power before you use the eject hole. If the CD/DVD is spinning when you open the drawer, the CD/DVD could fly off the spindle and cause injury.

- The CD/DVD extends slightly over the sides of the drawer so you can grasp it. Hold the CD/DVD gently and lift it out.

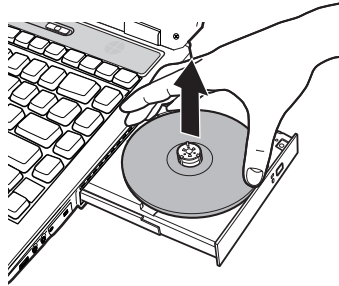

Removing a CD/DVD

- Push the centre of the drawer to close it. Press gently until it locks into place.

Audio/Video controls

This section describes how to use the audio/video control buttons.

Next and Previous buttons

A single button on a rocker controls the **Next** and **Previous** functions. Press on the icon to select the desired function.



▶▶	Next	Press the icon to advance to the next track, Chapter or data.
◀◀	Previous	Press the icon to skip to the previous track, Chapter or data.



If Random is selected in TOSHIBA Media Player, selecting Next or Previous advances to a random selection.

Play/Pause and Stop buttons

A single button on a rocker controls the **Play/Pause** and **Stop** functions. Press on the icon to select the desired function.

- | | | |
|---|-------------------|--|
|  | Play/Pause | Press the icon to begin or pause play. |
|  | Stop | Press the icon to stop play. |

Controls for CD/DVD and Digital Audio

CD/DVD control

Os is running and you press Play/Pause.

If an audio CD is in the optical media drive, TOSHIBA Media Player starts and CD audio play begins. If a DVD is in the optical media drive, the DVD Video player starts and DVD Video play begins.

Digital Audio control

TOSHIBA Media Player starts and Digital Audio Data play begins.

Writing to CDs with the CD RW/DVD ROM drive

Depending on the type of drive installed, you may be able to write CDs. The CD-RW/DVD-ROM drive lets you write as well as read CD-ROMs. Observe the precautions in this section to ensure the best performance for writing CDs. For information on loading and unloading CDs refer to the *Using optical media drives* section.



CD-R discs can be written to only once. CD-RW discs can be rewritten many times.

Before writing or rewriting

Please observe the following points when you write or rewrite the data.

- We recommend the following manufacturers of CD-R and CD-RW media. Media quality can affect write or rewrite success rates.

CD-R:	TAIYOYUDEN CO., LTD. MITSUBISHI CHEMICAL CORPORATION RICOH Co., Ltd. Hitachi Maxell Ltd.
CD-RW:	MITSUBISHI CHEMICAL CORPORATION RICOH Co., Ltd.

TOSHIBA has confirmed the operation of CD-R and CD-RW media of the manufacturers above. Operation of other media cannot be guaranteed.

- CD-RW can generally be rewritten about 1,000 times. However, the actual number of rewrites is affected by the quality of the media and the way it is used.
- Be sure to connect the universal AC adaptor when you write or rewrite.
- Be sure to close all other software programs except the writing software.
- Do not run software such as a screen saver which can put a heavy load on the CPU.
- Operate the computer at full power. Do not use power-saving features.
- Do not write while virus check software is running. Wait for it to finish, then disable virus detection programs including any software that checks files automatically in the background.
- Do not use hard disk utilities, including those intended to enhance HDD access speed. They may cause unstable operation and damage data.
- Write from the computer's HDD to the CD. Do not try to write from shared devices such as a LAN server or any other network device.

Writing CD/DVDs on DVD-R/-RW drive

You can use the DVD-R/-RW drive to write data to either CD-R/RW or DVD-R/-RW discs. The following applications for writing are supplied on CD-ROM: Drag'n Drop CD+DVD, licensed by Easy Systems Japan Ltd., and DigiOn Inc., InterVideo WinDVD Creator 2 Platinum, which is a product of InterVideo, Inc.

Important message

Before you write or rewrite to CD-R/RW or DVD-R/-RW disc, read and follow all set-up and operating instructions in this section. If you fail to do so, the DVD-R/-RW drive may not function properly, and you may fail to write or rewrite, lose data or incur other damage.



Also refer to the disc-writing instructions in the next section, Writing CD/DVDs on DVD Multi drive.

Disclaimer

TOSHIBA does not bear responsibility for the following:

- Damage to any CD-R/RW or DVD-R/-RW disc that may be caused by writing or rewriting with this product.
- Any change or loss of the recorded contents of CD-R/RW or DVD-R/-RW disc that may be caused by writing or rewriting with this product, or for any business profit loss or business interruption that may be caused by the change or loss of the recorded contents.
- Damage that may be caused by using third party equipment or software.

Given the technological limitations of current optical disc writing drives, you may experience unexpected writing or rewriting errors due to disc quality or problems with hardware devices. Also, it is a good idea to make two or more copies of important data, in case of undesired change or loss of the recorded contents.

Before writing or rewriting

Please observe the following points when you write or rewrite data.

- Based on TOSHIBA's limited compatibility testing, we suggest the following manufacturers of CD-R/RW and DVD-R/-RW/-RAM disc. However, in no event does TOSHIBA guarantee the operation, quality or performance of any disc. Disc quality can affect write or rewrite success rates.

CD-R: TAIYOYUDEN CO., LTD.
 MITSUBISHI CHEMICAL CORPORATION
 RICOH Co., Ltd.
 Hitachi Maxell Ltd.

CD-RW: MITSUBISHI CHEMICAL CORPORATION
 RICOH Co., Ltd.

DVD-R: **DVD Specifications for Recordable Disc for
 General Version 2.0**
 TAIYOYUDEN CO., LTD.
 PIONEER VIDEO CORPORATION
 MITSUBISHI CHEMICAL CORPORATION

DVD-RW: **DVD Specifications for Re-recordable Disc for
 Version 1.0 or Version 1.1**
 VICTOR COMPANY OF JAPAN, LIMITED
 TDK Corporation

- If the disc is poor in quality, dirty or damaged, writing or rewriting errors may occur. Be careful to check the disc for dirt or damage before you use it.
- The actual number of rewrites to CD-RW or DVD-RW/-RAM is affected by the quality of the disc and the way it is used.
- There are two types of DVD-R: authoring and general use discs. Do not use authoring discs. Only general use discs can be written to by a computer drive.
- Other DVD-ROM drives for computers or other DVD players may not be able to read DVD-R/-RW discs.

- You cannot overwrite data that has been previously written to a DVD-RW disc.
- You cannot partially delete any data written to a DVD-RW disc.
- Data written to a CD-R/DVD-R disc cannot be deleted either in whole or in part.
- Data deleted (erased) from a CD-RW and DVD-RW/-RAM disc cannot be recovered. Check the content of the disc carefully before you delete it. If multiple drives that can write data to discs are connected, be careful not to delete data from the wrong drive.
- In writing to a DVD-R/-RW disc, some disc space is required for file management, so you may not be able to write the full capacity of the disc.
- Since the disc is based on the DVD standard, it will be filled with dummy data if the written data is less than about 1 GB. Even if you write only a small amount of data, it might take time to fill in the dummy data.
- Two types of DVD-R/-RW discs are on the market: data and video. Use a video disc to store video data. You can use video discs on a DVD recorder as well as on your computer's DVD-ROM drive. You cannot use data discs on a DVD recorder.
- When multiple drives that can write data to discs are connected, be careful not to write to the wrong drive.
- Be sure to connect the universal AC adaptor before you write or rewrite.
- Be sure to close all other software programs except the writing software.
- Do not run software such as a screen saver, which can put a heavy load on the CPU.
- Operate the computer in the full-power mode. Do not use power-saving features.
- Do not write while virus check software is running. Wait for it to finish, then disable virus detection programs including any software that checks files automatically in the background.
- Do not use hard disk utilities, including those intended to enhance HDD access speed. They may cause unstable operation and data damage.
- Write from the computer's HDD to the CD/DVD. Do not try to write from shared devices such as a LAN server or any other network device.

Drag'n Drop CD+DVD

Note the following limitations when you use Drag'n Drop CD+DVD:

- DVD-Video cannot be created using Drag'n Drop CD+DVD.
- DVD-Audio cannot be created using Drag'n Drop CD+DVD.
- You cannot use Drag'n Drop CD+DVD's music CD function to record music to a DVD±RW disc.
- Do not use the DISC Backup function of Drag'n Drop CD+DVD to copy DVD-Video and DVD-ROM with copyright protection.
- DVD-RAM disc cannot be backed up with the DISC Backup function of Drag'n Drop CD+DVD.
- You cannot backup a CD-ROM or CD-R/RW to DVD±RW using the DISC Backup function of Drag'n Drop CD+DVD.
- You cannot back up DVD-ROM, DVD-Video or DVD±RW to CD-R/RW using the DISC Backup function of Drag'n Drop CD+DVD.
- Drag'n Drop CD+DVD cannot record in packet format.
- You might not be able to use the DISC backup function of Drag'n Drop CD+DVD to back up a DVD±RW disc that was made with other software on a different DVD±RW recorder.
- If you add data to a DVD± R disc that you have already recorded to, you might not be able to read the added data under some circumstances. It cannot be read in 16-bit operating systems, such as Windows 98SE and Windows ME. In Windows NT4, you will need Service Pack 6 or later to read added data. In Windows 2000, you will need Service Pack 2 or Later to read added data. Some DVD-ROM and CD-RW/DVD-ROM drives cannot read added data regardless of the operating system.
- Drag'n Drop CD+DVD does not support recording to DVD-RAM discs. To record to a DVD-RAM, use Explorer or other utility.
- If you try to back up a DVD disc to a DVD-RW disc that was erased by the Quick erase option, you might get a error message. Use the Full erase option to clear the DVD-RW disc and try again.
- When you back up a DVD disc, be sure the source drive supports recording to DVD±RW discs. If the source drive does not support recording to DVD±RW discs, it might not be backed up correctly.

Data verification

To verify that data is written or rewritten correctly, follow the steps below before you write or rewrite a Data CD/DVD.

1. Right-click **Data BOX** and select **Options** to display the **DATA DISC Option** window.
2. Mark the **Record and Verify** check box and select **Byte compare**.
3. Click the **OK** button.

The **Record and Verify** function automatically checks whether data has been correctly recorded onto a CD/DVD. **Byte compare** compares the original data file with the data recorded on the CD/DVD and checks that the data completely matches.

Media care

This section provides tips on protecting data stored on your CD/DVDs and diskettes.

Handle your media with care. The following simple precautions will increase the lifetime of your media and protect the data stored on them:

CD/DVDs

1. Store your CD/DVDs in the container they came in to protect them and keep them clean.
2. Do not bend the CD/DVD.
3. Do not write on, apply a sticker to, or otherwise mar the surface of the CD/DVD that contains data.
4. Hold the CD/DVD by its outside edge or the edge on the centre hole. Fingerprints on the surface can prevent the drive from properly reading data.
5. Do not expose to direct sunlight, extreme heat or cold. Do not place heavy objects on your CD/DVDs.
6. If your CD/DVDs become dusty or dirty, wipe them with a clean dry cloth. Wipe from the centre out, do not wipe in a circular direction around the CD/DVD. If necessary, use a cloth dampened in water or a neutral cleaner. Do not use benzene, thinner or similar cleaner.

Diskettes

1. Store your diskettes in the container they came in to protect them and keep them clean. If a diskette is dirty, do not use cleaning fluid. Clean it with a soft damp cloth.
2. Do not slide back the diskette's protective metal covering or touch the diskette's magnetic surface. Fingerprints may prevent the diskette drive from reading data from the diskette.
3. Data may be lost if the diskette is twisted; bent; or exposed to direct sunlight, extreme heat or cold.
4. Do not place heavy objects on your diskettes.
5. Do not eat, smoke, or use erasers near your diskettes. Foreign particles inside the diskette's jacket can damage the magnetic surface.
6. Magnetic energy can destroy data on diskettes. Keep your diskettes away from speakers, radios, television sets and other sources of magnetic fields.

Sound System

This section describes audio controls including sound levels and power management.

Volume control

The Volume Control utility lets you control the audio volume in Windows for both playback and recording.

- To launch Volume Control for playback, click **Start**, point to **All Programs**, point to **Accessories**, point to **Entertainment** and click **Volume Control**.
- To launch Recording Control, click **Options**, point to **Properties**, choose **Recording** and click **OK**.
- To view details of the Volume Control, click **Help** on the Volume Control.

Microphone level

To change the microphone gain, follow the steps below if you connect an external microphone to a microphone jack.



You need to purchase an optional external microphone if you would like to use the microphone functions.

1. Click **Start**, point to **All Programs**, point to **Accessories**, point to **Entertainment** and click **Volume Control**.
2. Click **Properties**, check the **Microphone** checkbox and click **OK**.
3. Click **Options** and select **Advanced Controls**.
4. Click **Advanced**.
5. Check the **MIC Boost** checkbox and click **Close**.

SoundMAX Control Panel

The SoundMAX control panel lets you control additional functions for the Microphone Enhancement and Audio Power Management. To launch the SoundMAX Control Panel, follow the steps below.

1. Click **Start** and click **Control Panel**.
2. If you are viewing the Control Panel in Category View, click on **Switch to Classic View**.
3. Double-click the **SoundMAX** icon.

Microphone Enhancements

The **Microphone Setup** allows you to optimise the microphone input settings for your particular configuration. Choose **Standard Microphone** if you have an ordinary desktop microphone. Choose **Headset** if you have a wearable microphone that is positioned directly in front of your mouth.

You can launch the **Setup Wizard** from the Control Panel to help you to automatically set proper microphone input volumes and ensure that your voice input(s) are working correctly. As you speak into the microphone, the Sound Meter indicates the audio signal that your PC is receiving.

The **Noise Reduction** enhancement helps to eliminate ambient noise from the voice input signal to provide a clean and clear signal to applications. This feature can be used with any microphone.

Power management

The audio controller can be powered down when the audio function is idle. To enable the Audio Power Management, follow the steps below.

1. Clicked the **Power Management** tab.
2. Select the **Normal Power Savings** in the Power Mode pull-down list.



If the No Power Savings is selected, the audio controller always runs.

If you want to a more effect for the power management, you can select another mode, the **High Power Savings** which can save the power than the Normal Power Savings. To select it, follow the steps below.

1. Clicked the **Power Management** tab.
2. Select the **High Power Savings** in the Power Mode pull-down list.
3. Input a time in **Power Save Delay (Seconds)**.



If the High Power Saving is selected, you need to play an audio file once before you use a microphone or play an audio CD by the analog CD audio.

Modem

This section describes how to connect and disconnect the internal modem to and from a telephone jack.



The internal modem does not support voice functions. All data and fax functions are supported.



In case of a lightning storm, unplug the modem cable from the telephone jack.

Do not connect the modem to a digital telephone line. A digital line will damage the modem.

Region selection

Telecommunication regulations vary from one region to another, so you will need to make sure the internal modem's settings are correct for the region in which it will be used.

To select a region, follow the steps below.

1. Click **start**, point to **All Programs**, point to **TOSHIBA** point to **Networking** and click **Modem Region Select**.



Do not use the Country/Region Select function in the Modem setup utility in the Control Panel if the function is available. If you change the Country/Region in the Control Panel, the change may not take effect.

2. The Region Selection icon will appear in the Windows Task Bar.



The Region Selection icon

3. Click the icon with the primary mouse button to display a list of regions that the modem supports. A sub menu for telephony location information will also be displayed. A check will appear next to the currently selected region and telephony location.
4. Select a region from the region menu or a telephony location from the sub-menu.
 - When you click a region it becomes the modem's region selection, and the New Location for telephony will be set automatically.
 - When you select a telephony location, the corresponding region is automatically selected and it becomes the modem's current region setting.

Properties menu

Click the icon with the secondary mouse button to display the following menu on the screen.

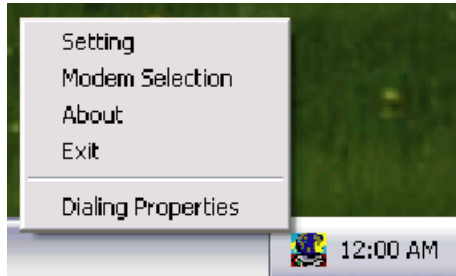

The menu list

Setting

You can enable or disable the following settings:

AutoRun Mode

The Region Select utility starts automatically when you start up the operating system.

Open the Dialling Properties dialog box after selecting region.

The dialling properties dialog box will be displayed automatically after you select the region.

Location list for region selection.

A submenu appears displaying location information for telephony.

Open dialog box, if the modem and Telephony Current Location region code do not match.

A warning dialog box is displayed if current settings for region code and telephony location are incorrect.

Modem Selection

If the computer cannot recognize the internal modem, a dialog box is displayed. Select the COM port for your modem to use.

Dialling Properties

Select this item to display the dialling properties.



If you are using the computer in Japan, the Telecommunications Business Law requires that you select Japan region mode. It is illegal to use the modem in Japan with any other selection.

Connecting

To connect the internal modem cable, follow the steps below.



The modular cable that comes with the computer must be used to connect a modem. Connect the end of the modular cable with the core to the computer.

In case of a lightning storm, unplug the modem cable from the telephone jack.

Do not connect the modem to a digital telephone line. A digital line will damage the modem.

Plug one end of the modular cable into the modem jack.

Plug the other end of the modular cable into a telephone jack.

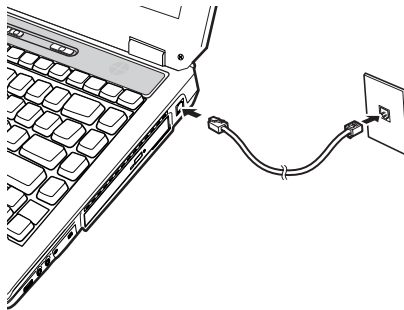

Connecting the internal modem



Do not pull on the cable or move the computer while the cable is connected.



If you use a storage device such as an optical media drive or HDD connected to a 16-bit PC card, modem speed might be slow or communication might be interrupted.

Disconnecting

To disconnect the internal modem cable, follow the steps below.

1. Pinch the lever on the connector in the telephone jack and pull out the connector.
2. Disconnect the cable from the computer in the same manner.
3. In the same way, pull the cable's other connector out of the computer.

LAN

LAN circuits support Ethernet LAN (10 megabits per second, 10BASE-T) and Fast Ethernet LAN (100 megabits per second, 100BASE-TX). This section describes how to connect/disconnect to a LAN.

LAN cable types



The computer must be configured properly before connecting to a LAN. Logging onto a LAN using the computer's default settings could cause a malfunction in LAN operation. Check with your LAN administrator regarding set-up procedures.

If you are using Fast Ethernet LAN (100 megabits per second, 100BASE-TX), be sure to connect with a CAT5 cable. You cannot use a CAT3 cable.

If you are using Ethernet LAN (10 megabits per second, 10BASE-T), you can connect with either a CAT5 or a CAT3.

Connecting LAN cable

To connect the LAN cable, follow the steps below.



Connect the AC adaptor before connecting the LAN cable. The AC adaptor must remain connected during LAN use. If you disconnect the AC Adaptor while the computer is accessing a LAN, the system may hang up. Do not connect any other cable to the LAN's jack except the LAN cable. Otherwise, malfunctions or damage may occur. Do not connect any power supplying device to the LAN cable that is connected to the LAN's jack. Otherwise, malfunctions or damage may occur.

1. Turn off the power to the computer and to all external devices connected to the computer.
2. Plug one end of the cable into the LAN jack. Press gently until you hear the latch click into place.

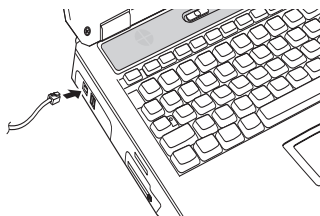

Connecting the LAN cable

3. Plug the other end of the cable into a LAN hub connector. Check with your LAN administrator before connecting to a hub.



*When the computer is exchanging data with the LAN, the **LAN Active** indicator glows orange. When the computer is connected to a LAN hub but is not exchanging data, the **Link** indicator glows green.*

Disconnecting LAN cable

To disconnect the LAN cable, follow the steps below.



*Make sure the **LAN Active** indicator (orange LED) is out before you disconnect the computer from the LAN.*

1. Pinch the lever on the connector in the computer's LAN jack and pull out the connector.
2. Disconnect the cable from the LAN hub in the same manner. Check with your LAN administrator before disconnecting from the hub.

Cleaning the computer

To help ensure long, trouble-free operation, keep the computer free of dust and use care with liquids around the computer.

- Be careful not to spill liquids into the computer. If the computer does get wet, turn the power off immediately and let the computer dry completely before you turn it on again.
- Clean the computer using a slightly damp (with water) cloth. You can use glass cleaner on the display. Spray a small amount of cleaner on a soft, clean cloth and wipe the screen gently with the cloth.



Never spray cleaner directly onto the computer or let liquid run into any part of it. Never use harsh or caustic chemical products to clean the computer.

- Remove the dust from the cooling vents on the Left side of the computer regularly with vacuum cleaner. Refer to the *Left side* section in Chapter 2, *The Grand Tour*.

Moving the computer

The computer is designed for rugged durability. However, a few simple precautions taken when moving the computer will help ensure trouble-free operation.

- Make sure all disk activity has ended before moving the computer. Check the **Built-in HDD** indicator on the computer and the indicator on any external disk drive.
- If a diskette is in the external disk drive, remove it.
- If a CD/DVD is in the drive, remove it. Also make sure the drawer is securely closed.
- Turn off the power to the computer.
- Disconnect the AC adaptor and all peripherals before moving the computer.
- Close the display. Do not pick up the computer by its display panel.
- Close all port covers.
- Use the carrying case when transporting the computer.

Heat dispersal

To protect from overheating, the CPU has an internal temperature sensor. If the computer's internal temperature rises to a certain level, the cooling fan is turned on or the processing speed is lowered. You can select whether to control the CPU temperature by turning on the fan first, then if necessary, lowering the CPU speed. Or, by lowering the CPU speed first, then if necessary, turning on the fan. Use the *Cooling Method* item of the *Basic Setup* tab in TOSHIBA Power Saver.

Maximum Performance	Turn on the fan first, then if necessary, lower the CPU processing speed.
Performance	Use a combination of the fan and lowering the CPU processing speed.
Battery optimised	Lower the CPU processing speed first, then if necessary turn on the fan.

When the CPU temperature falls to a normal range, the fan is turned off and the CPU operation returns to standard speed.



If the CPU temperature reaches an unacceptably high level with either setting, the system automatically shuts down to prevent damage. Data in memory will be lost.

The Keyboard

The computer's keyboard layouts are compatible with a 101/102-key enhanced keyboard. By pressing some keys in combination, all the 101/102-key keyboard functions can be executed on the computer.

The number of keys on your keyboard depends on which country/region's keyboard layout your computer is configured with. Keyboards for numerous languages are available.

There are five types of keys: typewriter keys, keypad overlay, function keys, soft keys and cursor control keys.

Typewriter keys

The typewriter keys produce the upper- and lower-case letters, numbers, punctuation marks, and special symbols that appear on the screen.

There are some differences, however, between using a typewriter and using a computer keyboard:

- Letters and numbers produced in computer text vary in width. Spaces, which are created by a "space character," may also vary depending on line justification and other factors.
- The lowercase l (el) and the number 1 (one) are not interchangeable on computers as they are on a typewriter.
- The uppercase O (oh) and the 0 (zero) are not interchangeable.
- The **Caps Lock** function key locks only the alphabetic characters in uppercase while the shift lock on a typewriter places all keys in the shifted position.
- The **Shift** keys, the **Tab** key, and the **BkSp** (backspace) key perform the same function as their typewriter counterparts but also have special computer functions.

F1...F12 function keys

The function keys, not to be confused with **Fn**, are the 12 keys at the top of your keyboard. These keys function differently from other keys.



F1 through **F12** are called function keys because they execute programmed functions when pressed. Used in combination with the **Fn** key, keys marked with icons execute specific functions on the computer. See the section *Soft keys: Fn key combinations* in this chapter. The function executed by individual keys depends on the software you are using.

Soft Keys: Alt Gr Key Combinations



The **Alt Gr** key, at the right of the space bar, is used in combination with other keys to create accented or special characters (#,@,|, etc.). Note that some of the keys at the top of the keyboard bear three symbols (not to be confused with the blue or white letters on the side of some other keys). To generate the third symbol, hold **Alt Gr** and press the key bearing the character you wish to create. Please note that since the **Alt Gr** key is not present on the American keyboard, it cannot be used if you have installed an American keyboard driver.

Soft keys: Fn key combinations

The **Fn** (function) is unique to TOSHIBA computers and is used in combination with other keys to form soft keys. Soft keys are key combinations that enable, disable or configure specific features.



Some software may disable or interfere with soft-key operations. Soft-key settings are not restored by the Standby feature.

Emulating keys on enhanced keyboard

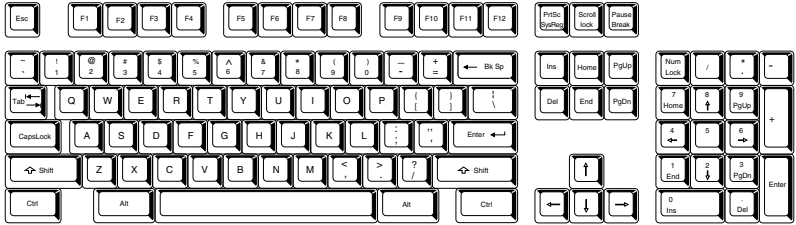

A 101-key enhanced keyboard layout

The keyboard is designed to provide all the features of the 101-key enhanced keyboard, shown above. The 101/102-key enhanced keyboard has a numeric keypad and scroll lock key. It also has additional **Enter** and **Ctrl** keys to the right of the main keyboard. Since the keyboard of a portable computer is smaller and has fewer keys, some of the enhanced keyboard functions must be simulated using two keys instead of one on the larger keyboard.

Your software may require you to use keys that the keyboard does not have. Pressing the **Fn** key and one of the following keys simulates the enhanced keyboard's functions.



Press **Fn + F10** or **Fn + F11** to access the integrated keypad. When activated, the keys with grey markings on the bottom edge become numeric keypad keys (**Fn + F11**) or cursor control keys (**Fn + F10**). Refer to the *Keypad overlay* section in this Chapter for more information on how to operate these keys. The power on default for both settings is off.



Press **Fn + F12 (ScrLock)** to lock the cursor on a specific line. The power on default is off.



Press **Fn + Enter** to simulate **Enter** on the enhanced keyboard's numeric keypad.



Press **Fn + Ctrl** to simulate the enhanced keyboard's right **Ctrl** key.

Hot keys

Hot keys (**Fn** + a function or Esc key) let you enable or disable certain features of the computers.



Sound mute: Pressing **Fn** + **Esc** in a Windows environment turns sound on or off. When you press these hot keys, the current setting will change and be displayed as an icon.



Instant security: Press **Fn** + **F1** to blank the screen to prevent others from accessing your data. To restore the screen and original settings, press any key or press the Touch Pad. If a screensaver password is registered, a dialog box will appear. Enter the screensaver password and click **OK**. If no password is set, the screen will be restored when you press any key or press the Touch Pad.



Power save mode: Pressing **Fn** + **F2** changes the power save mode.

If you press **Fn** + **F2** in a Windows environment, the Power Save Mode is displayed in a dialog box similar to the one below. Continue holding down **Fn** and press **F2** again to change the setting. You can also change this setting through the *Profile* item in Power Saver.



Standby: When you press **Fn** + **F3**, the computer enters Standby. To avoid entering Standby unexpectedly, a dialog box appears for verification. However, if you select the check box, it will not appear in the future.



Hibernation: When you press **Fn** + **F4**, the computer enters Hibernation. To avoid entering Hibernation unexpectedly, a dialog box appears for verification. However, if you select the check box, it will not appear in the future.



Display selection: Press **Fn + F5** to change the active display device. When you press these hot keys a dialog box appears. Only selectable devices will be displayed. Hold down **Fn** and press **F5** again to change the device. When you release **Fn** and **F5**, the selected device will change. If you hold down the keys for three seconds the selection will return to **LCD**.



LCD Display Brightness: Pressing **Fn + F6** decreases the display brightness in decrements. When you press these hot keys, the current setting will be displayed for two seconds by an icon. You can also change this setting through the *Screen brightness* item of the *Basic Setup* tab in Power Saver.



LCD Display Brightness: Pressing **Fn + F7** increases the display brightness in increments. When you press these hot keys, the current setting will be displayed for two seconds by a pop-up icon. You can also change this setting through the *Screen brightness* item of the *Basic Setup* tab in Power Saver.



Display clarity increases with the brightness level.



Wireless setting: If your computer has wireless LAN functions, you can press **Fn + F8** to select which type of wireless communication you want to use. When you press these hot keys, a dialog box will appear. Continue holding down **Fn** and press **F8** to change the setting. If wireless communication is turned off, **Disabled Wireless Communication Switch** will be displayed.



If no wireless communication device is installed, no dialog box will appear.



Touch pad: Pressing **Fn + F9** enables or disables the Touch pad function. When you press these hot keys, the current setting will change and be displayed as an icon.

Fn Sticky key

You can use the TOSHIBA Accessibility Utility to make the **Fn** key sticky, that is, you can press it once, release it, and then press an **F number** key. To start the TOSHIBA Accessibility Utility, click **start**, point to **All Programs**, point to **TOSHIBA**, point to **Utilities** and click **Accessibility**.

Windows special keys

The keyboard provides two keys that have special functions in Windows : one activates the **start** menu and the other has the same function as the secondary mouse button.



This key activates the Windows **start** menu.



This key has the same function as the secondary mouse button.

Keypad overlay

Your computer's keyboard does not have an independent numeric keypad, but its numeric keypad overlay functions like one.

The keys in the centre of the keyboard with grey letters make up the numeric keypad overlay. The overlay provides the same functions as the numeric keypad on the 101/102-key enhanced keyboard.

Turning on the overlays

The numeric keypad overlay can be used for numeric data input or cursor and page control.

Arrow mode

To turn on the Arrow mode, press **Fn + F10**. The Arrow mode **F10** indicator lights. Now try cursor and page control using the keys shown below. Press **Fn + F10** again to turn off the overlay.

Numeric mode

To turn on the Numeric mode, press **Fn + F11**. The Numeric mode **F11** indicator lights. Now try numeric data entry using the keys shown below. Press **Fn + F11** again to turn off the overlay.

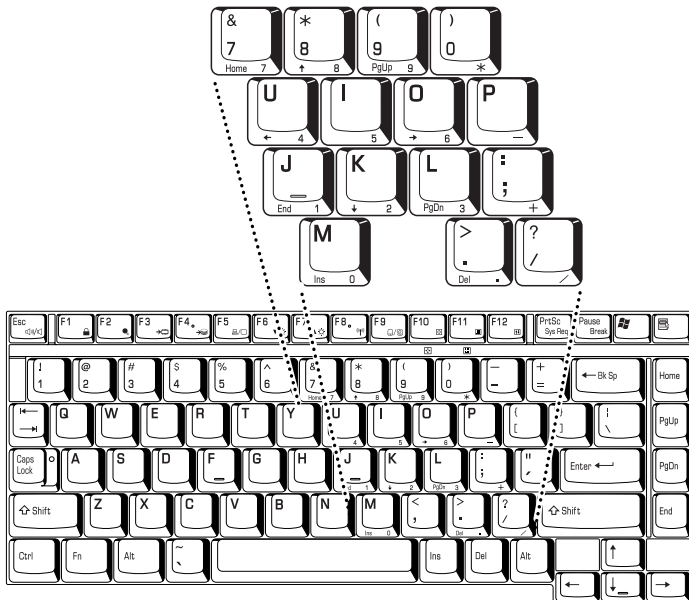

The numeric keypad overlay

Temporarily using normal keyboard (overlay on)

While using the overlay, you can temporarily access the normal keyboard without turning off the overlay:

1. Hold **Fn** and press any other key. All keys will operate as if the overlay were off.
2. Type upper-case characters by holding **Fn + Shift** and pressing a character key.
3. Release **Fn** to continue using the overlay.

Temporarily using overlay (overlay off)

While using the normal keyboard, you can temporarily use the keypad overlay without turning it on:

1. Press and hold down **Fn**.
2. Check the keyboard indicators. Pressing **Fn** turns on the most recently used overlay. If the **Numeric mode** icon lights, you can use the overlay for numeric entry. If the **Arrow mode** icon lights, you can use the overlay for cursor and page control.
3. Release **Fn** to return to normal keyboard operation.

Temporarily changing modes

If the computer is in **Numeric mode**, you can switch temporarily to **Arrow mode** by pressing a shift key.

If the computer is in **Arrow mode**, you can switch temporarily to **Numeric mode** by pressing a shift key.

Generating ASCII characters

Not all ASCII characters can be generated using normal keyboard operation. But, you can generate these characters using their ASCII codes.

With the overlay on:

1. Hold down **Alt**.
2. Using the overlay keys, type the ASCII code.
3. Release **Alt**, and the ASCII character appears on the display screen.

With the overlay off:

1. Hold **Alt + Fn**.
2. Using the overlay keys, type the ASCII code.
3. Release **Alt + Fn**, and the ASCII character appears on the display screen.

A list of ASCII characters with their codes is shown in Appendix F.

Power and Power-Up Modes

The computer's power resources include the AC adaptor and internal batteries. This Chapter gives details on making the most effective use of these resources including charging and changing batteries, tips for saving battery power, and power up modes.

Power conditions

The computer's operating capability and battery charge status are affected by the power conditions: whether an AC adaptor is connected, whether a battery is installed and what the charge level is for the battery.

		Power on	Power off (no operation)
AC adaptor connected	Battery fully charged	<ul style="list-style-type: none"> Operates LED: Battery green DC IN 15V green 	<ul style="list-style-type: none"> LED: Battery green DC IN 15V green
	Battery partially charged or no charge	<ul style="list-style-type: none"> Operates Quick charge LED: Battery orange DC IN 15V green 	<ul style="list-style-type: none"> Quick charge LED: Battery orange DC IN 15V green
	No battery installed	<ul style="list-style-type: none"> Operates No charge LED: Battery off DC IN 15V green 	<ul style="list-style-type: none"> No charge LED: Battery off DC IN 15V green

		Power on	Power off (no operation)
AC adaptor not connected	Battery charge is above low battery trigger point	<ul style="list-style-type: none"> Operates LED: Battery off DC IN 15V off 	—
	Battery charge is below low battery trigger point	<ul style="list-style-type: none"> Operates LED: Battery flashes orange DC IN 15V off 	—
	Battery charge exhausted	Computer goes into resume mode and shuts down	—
	No Battery installed	<ul style="list-style-type: none"> Cannot operate LED: Battery off DC IN 15V off 	—

Power indicators

As shown in the above table, the **Battery**, **DC IN 15V** and **Power** indicators on the system indicator panel alert you to the computer's operating capability and battery charge status.

Battery indicator

Check the **Battery** indicator to determine the status of the battery. The following indicator lights indicate the battery status:

Flashing orange	The battery charge is low. The AC adaptor must be connected to recharge the battery.
Orange	Indicates the AC adaptor is connected and charging the battery.
Green	Indicates the AC adaptor is connected and the battery is fully charged.
No light	Under any other conditions, the indicator does not light.



If the battery becomes too hot while it is being charged, the charge will stop and the battery indicator will go out. When the battery's temperature falls to a normal range, charge will resume. This occurs whether the computer's power is on or off.

DC IN 15V indicator

Check the **DC IN 15V** indicator to determine the power status from the AC adaptor connected:

Green	Indicates the AC adaptor is connected and supplying proper power to the computer.
Flashing orange	Indicates a problem with the power supply. Plug the AC adaptor into another outlet. If it still does not operate properly, see your dealer.
No light	Under any other conditions, the indicator does not light.

Power indicator

Check the **Power** indicator to determine the power status:

Green	Indicates power is being supplied to the computer and the computer is turned on.
Blinking orange	Indicates power is being supplied to the computer while the computer is in Standby mode.
No light	Under any other conditions, the indicator does not light.

Battery types

The computer has two types of batteries:

- Battery pack: 12-cell battery pack is available 8400mAh.
- Real Time Clock (RTC) battery

Battery pack

When the AC adaptor is not connected, the computer's main power source is a removable lithium-ion battery pack, also referred to in this manual as the battery pack. You can purchase additional battery packs for extended use of the computer away from an AC power source.

Before you remove the battery pack, set the computer to Hibernation mode or save your data and shut down the computer. Do not change the battery pack while the AC adaptor is connected.



The battery pack is a lithium-ion battery, which can explode if not properly replaced, used, handled or disposed of. Dispose of the battery as required by local ordinances or regulations. Use only batteries recommended by TOSHIBA as replacements.

Do not remove the battery pack while the computer is in Standby mode. Data is stored in RAM, so if the computer loses power it will be lost. When the computer is powered off in Standby mode, and the universal AC adaptor is not connected, the battery pack supplies power to maintain data and program in memory. If the battery pack is completely discharged, Standby mode does not function and the computer loses all data in memory.

To ensure that the battery pack maintains its maximum capacity, operate the computer on battery power at least once a month until the battery pack is fully discharged. Refer to *Extending battery life* in this Chapter for procedures. If the computer is continuously operated on AC power through an AC adaptor for an extended period, more than a month, the battery may fail to retain a charge. It may not function efficiently over the expected life of the battery and the **Battery** indicator may not indicate a low-battery condition.

Real Time Clock battery

The Real Time Clock (RTC) battery provides power for the internal real time clock and calendar. It also maintains the system configuration.

If the RTC battery becomes completely discharged, the system loses this data and the real time clock and calendar stop working. The following message appears when you turn on the power:



```
**** RTC battery is low or CMOS checksum is
inconsistent ) ****
Press [F1] key to set Date/Time.
```



The computer's RTC battery is a nickel metal hydride battery and should be replaced only by your dealer or by a TOSHIBA service representative. The battery can explode if not properly replaced, used, handled or disposed of. Dispose of the battery as required by local ordinances or regulations.



*You can change the setting of RTC by pressing **F1** key. Refer to Chapter 9, Troubleshooting, for details.*

Care and use of the battery pack

The battery pack is a vital component of portable computing. Taking proper care of it will help ensure longer operating time on battery power as well as a longer life for your battery pack. Follow the instructions in this section carefully to assure safe operation and maximum performance.

Safety precautions

Mishandling of batteries can cause death, serious injury or property damage. Carefully observe the following advisories:

Danger: Indicates an imminently hazardous situation, which could result in death or serious injury, if you do not follow instructions.

Warning: Indicates a potentially hazardous situation, which could result in death or serious injury, if you do not follow instructions.

Caution: Indicates a potentially hazardous situation, which if not avoided, may result in moderate or minor injury or property damage.

Note: Provides important information.

Danger

1. Never try to dispose of the battery pack by burning or expose it to a heating device such as a microwave oven. The battery pack could explode and cause bodily injury.
2. Never try to disassemble, repair or otherwise tamper with a battery pack. The battery pack will overheat and ignite. Leakage of caustic alkaline solution or other electrolytic substances will cause fire or injury, possibly resulting in death or serious injury.
3. Never short-circuit the battery pack by contacting the terminals with a metal object. A short-circuit can cause fire or otherwise damage the battery pack and possibly cause injury. To avoid accidental short-circuit, always wrap the battery pack in plastic and cover the terminals with electrical tape when storing or disposing of the battery pack.
4. Never puncture the battery pack with a nail or other sharp object. Never strike it with a hammer or other object. Never step on it.
5. Never try to charge the battery pack in any manner other than that described in the user's manual. Never connect the battery pack to a plug socket or to a automobile's cigarette lighter socket. It may rupture or ignite.
6. Use only the battery pack supplied with the computer or other device or an battery pack approved by the computer or device's manufacturer. Battery packs have different voltages and terminal polarities. Use of an improper battery could cause smoke, fire or rupture of the battery pack.
7. Never subject a battery pack to heat, such as storage near a heat source. Exposure to heat can cause the battery pack to ignite, explode or leak caustic liquid and cause death or serious injury. It could also fail or malfunction causing data loss.
8. Never expose the battery pack to abnormal shock, vibration or pressure. The battery pack's internal protective device will fail, causing it to overheat, explode, ignite or leak caustic liquids possibly resulting in death or serious injury.
9. Never let a battery pack become wet. A wet battery pack will overheat, ignite or rupture possibly resulting in death or serious injury.

Warning

1. Never allow caustic electrolyte fluid leaked from a battery pack to contact your eyes, skin or clothing. If caustic electrolyte fluid should contact your eyes, immediately wash your eyes with large amounts of running water and seek medical attention, to help prevent eye damage. If electrolyte fluid should contact your skin immediately wash it under running water to prevent rash. If it contacts your clothes, promptly remove them to prevent the fluid from contacting your skin or eyes.
2. Immediately turn off the power, disconnect the AC adaptor and remove the battery if any of the following events are observed in the battery pack: offensive or unusual odour, excessive heat, discoloration or deformation. Never use the computer again until it has been checked by a TOSHIBA service provider. It might generate smoke or fire, or the battery pack might rupture.
3. Make sure the battery is securely installed in the computer before attempting to charge the battery pack. Improper installation could generate smoke or fire, or cause the battery pack to rupture.
4. Keep the battery pack out of reach of infants and children. It can cause injury.

Caution

1. Never continue to use a battery pack after its recharging capacity has become impaired, or after the display of a warning message indicating that the battery pack's power is exhausted. Continued use of an exhausted or impaired battery pack could cause the loss of data.
2. Never dispose of battery packs with normal trash. Bring them to your TOSHIBA dealer or to another recycling centre to save resources and prevent environmental damage. Cover the terminals with electrical tape to prevent short-circuits, which could cause the battery pack to ignite or rupture.
3. Use only battery packs recommended by TOSHIBA as replacements.
4. Always make sure the battery pack is installed correctly and securely. Otherwise, a battery pack could fall out and possibly cause injury.
5. Charge the battery pack only in an ambient temperature between 5 and 35 degrees Celsius. Otherwise, the electrolyte solution might leak, battery pack performance might deteriorate and the battery life might be shortened.
6. Be sure to monitor the remaining battery power. If the battery pack and real time clock battery discharge completely, Standby and Suspend will not function and data in memory will be lost. Also, the computer might register an incorrect time and date. In this case, connect the AC adaptor to recharge the batteries.
7. Never install or remove the battery pack without first turning off the power and disconnecting the AC adaptor. Never remove the battery pack while the computer is in Standby mode. Data will be lost.

Note

1. Never remove the battery pack while the Wake-up on LAN function is enabled. Data will be lost. Before you remove a battery pack, disable the Wake-up on LAN function.
2. To ensure the battery pack maintains maximum capacity, operate the computer on battery power once a week until the battery pack is fully discharged. Refer to the section *Extending battery life* in this Chapter for procedures. If the computer is continuously operated on AC power for an extended period, more than a week, the battery might fail to retain a charge. It might not function efficiently over the expected life of the battery pack and the **Battery** indicator might not indicate a low-battery condition.
3. After the battery pack is charged, avoid leaving the AC adaptor connected and the computer turned off for more than a few hours at a time. Continuing to charge a fully-charged battery pack can damage the battery.

Charging the batteries

When the power in the battery pack becomes low, the **Battery** indicator flashes orange indicating that only a few minutes of battery power remain. If you continue to use the computer while the **Battery** indicator flashes, the computer enables Hibernation mode (so you don't lose data) and automatically turns off.



The computer enters Hibernate mode only if Hibernation is enabled in two places : the Hibernate tab in Power Options and Setup Action tab in TOSHIBA Power Saver.

You must recharge a battery pack when it becomes discharged.

Procedures

To recharge a battery pack while it is installed in the computer, connect the AC adaptor to the **DC IN 15V** socket and plug the other end into a working outlet.

The **Battery** indicator glows orange when the battery is being charged.



Use only the computer connected to an AC power source to charge the battery pack. Never attempt to charge the battery pack with any other charger.

Time

The following table shows the approximate time required to fully charge a discharged battery.

Battery type	Charging time (hours)	
	Power on	Power off
Battery pack 8400mAh	7 to 20 or longer	about 3.5
RTC battery	8	Doesn't charge



The charging time when the computer is on is affected by ambient temperature, the temperature of the computer and how you use the computer. If you make heavy use of external devices, for example, the battery might scarcely charge at all during operation. Refer also to the section Maximising battery operating time.

The charge time of a battery changes with the apparatus composition and the situation of operation of a personal computer, or the specifications of AC adaptor.

Battery charging notice

The battery may not charge right away under the following conditions:

- The battery is extremely hot or cold. If the battery is extremely hot, it might not charge at all. To ensure the battery charges to its full capacity, charge the battery at room temperature of 10° to 30°C (50° to 88°F).
- The battery is nearly completely discharged. Leave the AC adaptor connected for a few minutes and the battery should begin charging.

The **Battery** indicator may show a rapid decrease in battery operating time when you try to charge a battery under the following conditions:

- The battery has not been used for a long time.
- The battery has completely discharged and been left in the computer for a long time.
- A cool battery is installed in a warm computer.

In such case, follow the steps below.

1. Fully discharge the battery by leaving it in the computer with the power on until the power automatically shuts off.
2. Plug in the AC adaptor.
3. Charge the battery until the **Battery** indicator glows green.

Repeat these steps two or three times until the battery recovers normal capacity.



Leaving the AC adaptor connected will shorten battery life. At least once a month, run the computer on battery power until the battery is fully discharged, then recharge the battery.

Monitoring battery capacity

Remaining battery power can be monitored in Power Saver.



Wait at least 16 seconds after turning on the computer before trying to monitor the remaining operating time. The computer needs this time to check the battery's remaining capacity and to calculate the remaining operating time, based on the current power consumption rate and remaining battery capacity. The actual remaining operating time may differ slightly from the calculated time.

With repeated discharges and recharges, the battery's capacity will gradually decrease. Therefore, an often used, older battery will not operate for as long as a new battery even when both are fully charged. In this case, TOSHIBA Power Saver will indicate a 100% charge for both the old and new battery, but the displayed estimated time remaining will be shorter for the older battery.

Maximising battery operating time

A battery's usefulness depends on how long it can supply power on a single charge.

How long the charge lasts in a battery depends on:

- How you configure the computer, for example, whether you enable battery-power saving options. The computer provides a battery save mode, which can be set in TOSHIBA Power Saver, to conserve battery power. This mode has the following options:
 - CPU Processing speed
 - Screen brightness
 - System standby
 - System Hibernation
 - Monitor Power off
 - HDD Power off
- How often and how long you use the hard disk and the diskette drive.
- How much charge the battery contained to begin with.
- How you use optional devices, such as a PC card, to which the battery supplies power.
- Enabling Standby mode conserves battery power if you are frequently turning the computer off and on.
- Where you store your programs and data.
- Closing the display when you are not using the keyboard saves power.
- Operating time decreases at low temperatures.
- The condition of the battery terminals. Make sure the battery terminals stay clean by wiping them with a clean dry cloth before installing the battery pack.

Retaining data with power off

When you turn off your computer with fully charged batteries, the computer will retain data for the following approximate time periods:

Battery pack 8400mAh	about 6 days (Standby mode)
	about 2 months(Boot mode)
RTC battery	1 month

Extending battery life

To maximise the life of your battery pack:

- At least once a month, disconnect the computer from a power source and operate it on battery power until the battery pack fully discharges. Before doing so, follow the steps below.
 1. Turn off the computer's power.
 2. Disconnect the AC adaptor and turn on the computer's power. If it does not turn on go to step 4.
 3. Operate the computer on battery power for five minutes. If the battery pack has at least five minutes of operating time, continue operating until the battery pack is fully discharged. If the **Battery** indicator flashes or there is some other warning to indicate a low battery, go to step 4.
 4. Connect the AC adaptor to the computer and the power cord to a power outlet. The **DC IN 15V** indicator should glow green, and the **Battery** indicator should glow orange to indicate that the battery pack is being charged. If the **DC IN 15V** indicator does not glow, power is not being supplied. Check the connections for the AC adaptor and power cord.
 5. Charge the battery pack until the **Battery** indicator glows green.
- If you have extra battery packs, rotate their use.
- If you will not be using the system for an extended period, more than one month, remove the battery pack.
- Disconnect the AC adaptor when the battery is fully charged. Overcharging makes the battery hot and shortens life.
- If you are not going to use the computer for more than eight hours, disconnect the universal AC adaptor.
- Store spare battery packs in a cool dry place out of direct sunlight.

Replacing the battery pack

When the battery pack reaches the end of its operating life you will need to install a new one. The life of the battery pack is generally about 500 recharges. If the **Battery** indicator flashes orange shortly after fully recharging the battery, the battery pack needs to be replaced.

You might also replace a discharged battery pack with a charged spare when you are operating your computer away from an AC power source. This section explains how to remove and install the battery pack.

Removing the battery pack

To replace a discharged battery, follow the steps below. Refer to Chapter 2, *The Grand Tour*, for component locations.



When handling battery packs, be careful not to short circuit the terminals. Also do not drop, hit or otherwise apply impact; do not scratch or break the casing and do not twist or bend the battery pack.

Do not remove the battery pack while the computer is in Standby mode. Data is stored in RAM, so if the computer loses power it will be lost.

*In Hibernation mode, data will be lost if you remove the battery and disconnect the universal AC adaptor before the save is completed. Wait for the **Built-in HDD** indicator to go out.*

Do not touch the latch while holding the computer, or you may get injured by the dropped battery by unintentional release of the latch.

1. Save your work.
2. Turn the computer's power off. Make sure the **Power** indicator is off.
3. Remove all cables connected to the computer.
4. Turn the computer upside down.

5. Slide the battery release latch to free the battery pack for removal after switching the battery safety lock into unlock position (direction opposite to the battery), then slide out the battery pack.

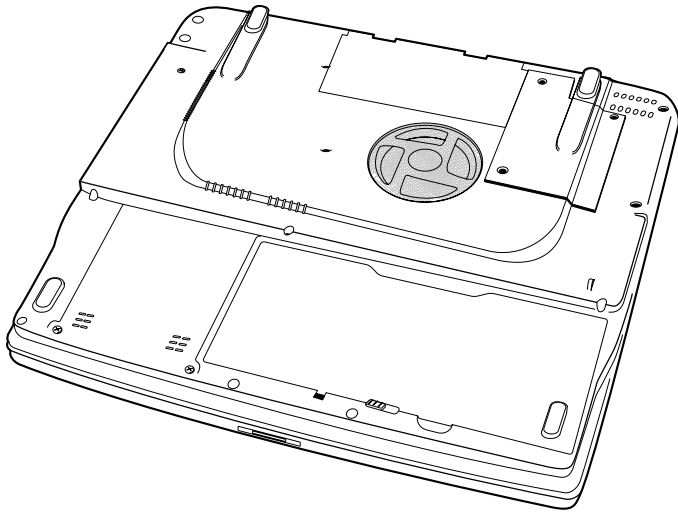

Releasing the battery pack



For environmental reasons, do not throw away a spent battery pack. Please return spent battery packs to your TOSHIBA dealer.

Installing the battery pack

To install a battery pack, follow the steps below.



The battery pack is a lithium-ion battery, which can explode if not properly replaced, used, handled or disposed of. Dispose of the battery as required by local ordinances or regulations. Use only batteries recommended by TOSHIBA as replacements.

Do not touch the latch while holding the computer, or you may get injured by the dropped battery by unintentional release of the latch.

1. Turn the computer's power off.
2. Disconnect all cables connected to the computer.
3. Insert the battery pack.
4. Secure the battery pack lock. Switch the battery safety lock into lock position.(direction toward the battery)

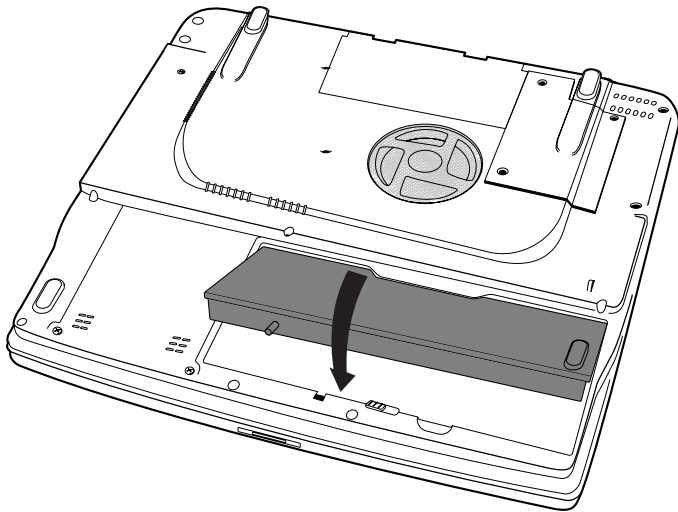

Securing the battery pack

Starting the computer by password

To start up the computer with the user password, follow these steps:

1. Turn on the power as described in Chapter 3, *Getting Started*. The following message appears:



Password =



*At this point, the hot keys **Fn + F1** to **F5** do not work. They will function after you enter the password.*

2. Enter the password.
3. Press **Enter**.



If you enter the password incorrectly three times in a row, the computer shuts off. In this case, you must turn the computer back on to retry password entry.

Power-up modes

The computer has the following power-up modes:

- **Boot:** Computer shuts down without saving data. Always save your work before you turn the computer off in boot mode.
- **Hibernation:** Data in memory is saved to the hard disk.
- **Standby:** Data is maintained in the computer's main memory.



*Refer also to the sections *Turning on the power* and *Turning off the power* in Chapter 3, *Getting Started*.*

Windows utilities

You can specify the setting in TOSHIBA Power Saver.

Hot keys

You can use hot keys **Fn + F3** to enter Standby mode and **Fn + F4** to enter Hibernation. See Chapter 5, *The Keyboard* for details.

Panel power on/off

You can set up your computer so that power turns off automatically when you close the display panel. When you open the panel, power turns on in Standby or Hibernation mode but not in boot mode.



If the panel power off function is enabled and you use Shut down Windows, do not close the display until the shut down function is completed.

System Auto Off

This feature turns the system off automatically if it is not used for a set duration. The system shuts down in Standby mode or Hibernation mode in Windows.

HW Setup and Passwords

This Chapter explains how to use TOSHIBA HW Setup program to configure your computer and how to set passwords.

HW Setup

TOSHIBA HW Setup lets you configure settings for Display, CPU, Boot Priority, Keyboard, USB, LAN, General, Password, Device Config and Parallel/Printer.



If the supervisor password is set, access to the TOSHIBA HW Setup program can be prevented when the user password is used to log on to the computer. Some models are not equipped with Parallel/Printer tab and/or CPU tab.

Accessing HW Setup

To run HW Setup, click **start**, click **Control Panel** and select **TOSHIBA HW Setup**.

HW Setup window

The HW Setup window contains the following tabs: General, Password, Device Config, Parallel/Printer, Display, CPU, Boot Priority, Keyboard, USB and LAN.



Some models are not equipped with Parallel/Printer and/or CPU tabs.

There are also three buttons: OK, Cancel and Apply.

OK	Accepts your changes and closes the HW Setup window.
Cancel	Closes the window without accepting your changes.
Apply	Accepts all your changes without closing the HW Setup window.

General

This window displays the BIOS version and contains two buttons: **Default** and **About**.

Default	Return all HW Setup values to the factory settings.
About	Display the HW Setup version.

Setup

This field displays **BIOS Version** and date.

Password

User Password

This option allows you to set or reset the user password for power on.

Not Registered	Change or remove the password. (Default)
Registered	Set the password. A dialog box will appear to let you set the password.

To enter a user password:

1. Select **Registered** to display the following prompt:



Enter Password:

2. Enter a password of up to 10 characters. (You cannot use the following characters: - ^ @ [] ; : , . / **space**.) The character string you enter is displayed as a string of asterisks. For example, if you enter a password consisting of four characters, the display is shown as:



Enter Password: ****



If you click the **OK** button before entering the password, **Not registered** will appear on the display.

- Click the **OK** button. The following message appears, allowing you to verify the password.



Verify Password:

- If character strings match, the password is registered and the display changes to:



The password was registered

If they do not match, the following message appears. You must repeat from step 1.



Entry Error!!!

To delete a user password:

- Select **Not Registered** to display the following prompt:



Enter Password:

- Enter the currently registered password. The character string you enter is displayed as a string of asterisks.



Enter Password: ****



*If you click the **OK** button before entering the password, **Registered** will appear on the display.*

- Click the **OK** button. If the character string you enter matches the registered password, the password option is reset and the display changes to:



The password was deleted

If they do not match, the following message appears. You must repeat step 1.



Incorrect Password



*If you enter the password incorrectly three times, the screen will display: **Sorry, access denied!!! Powering off your machine then powering it back on again are required to regain access.***

You will not be able to access the password option in the HW Setup. In this case you must turn the power off and back on to retry the procedure.

- Follow the same procedures described in the earlier section, *How to set the password*, to set a new user password.

Refer to the *Supervisor password* section later in this Chapter for details on setting the supervisor password.

Key FD

After you set a password, you can create a Key FD (diskette). If you forget the user password, the Key FD lets you bypass the password function.



It is a good idea to create more than one Key FD in case a Key FD is damaged or lost.

To create a Key FD follow the steps below.

1. Turn off the computer's power.
2. Connect the diskette drive to a USB port on the computer.
3. Set a diskette's write-protect tab to the write enable position and insert the diskette in the drive.



All data on the diskette will be destroyed.

4. Turn on the computer's power.



Password=

will be displayed on the LCD.

5. Enter the password.
6. Press the Tab key.



Insert FD Ready (Y/N)

will be displayed on the LCD.

7. Press Y.



Remove FD press key

will be displayed on the LCD.

8. Remove the diskette and press any key.

Device Config

Device Configuration

This option lets you set the device configuration.

All Devices	BIOS sets all devices.
Setup by OS	Operating system sets devices that it can control. (Default)

Parallel/Printer

Some models are equipped with Parallel/Printer tab. This tab lets you set the Parallel Port Mode. Use the Windows Device Manager to make settings for the Parallel port.

Parallel Port Mode

The options in this tab are **ECP** and **Standard Bi-directional**.

ECP	Sets the port type to Extended Capabilities Port (ECP). For most printers, the port should be set to ECP . (Default)
------------	---

Standard Bi-directional	This setting should be used with some other parallel devices.
--------------------------------	---

Display

This tab lets you customize your computer's display settings for either the internal LCD screen or for an external monitor.

Power On Display

Lets you use the display to be used when the computer is booted. (This setting is only available on Standard VGA mode and not available on Windows Desktop)

Auto-Selected	Selects an external monitor if one is connected. Otherwise, it selects the internal LCD. (Default)
----------------------	--

LCD + Analog RGB	Selects both the internal LCD and external monitor for simultaneous display.
-------------------------	--

CPU

Celeron models are not equipped with CPU tab.

This function lets you set the CPU operating mode.

Dynamic CPU Frequency Mode

This option lets you choose from the following settings:

Dynamically Switchable	CPU power consumption and clock speed automatic switching function is enabled. When the computer is in use, CPU operation is automatically switched when necessary. (Default)
Always High	CPU power consumption and clock speed automatic switching function is disabled. The CPU always runs at its fastest speed.
Always Low	CPU power consumption and clock speed automatic switching function is disabled. The CPU always runs at low power consumption and low speed.

HT Technology

This tab is available only on the models with the CPU that supports Hyper-Threading Technology (HTT). You can enable or disable the HTT feature (including control for PM when enabling it) using this tab.

Enabled with PM*	Select this option to enable the HTT feature with PM activated.
Enabled without PM*	Select this option to enable the HTT feature with PM deactivated.
Disabled	Select this option to disable the HTT feature.

* PM is Power Management's abbreviation.



This tab appears only on the models with the CPU that supports the HTT feature. The options on this tab will not change to their default settings even if you press the Default button on the General tab. Also note that the Dynamically Switchable setting in the Dynamic CPU Frequency Mode option is not available when the Enabled without PM option is selected on this tab.

Boot Priority

Boot Priority Options

This option sets the priority for booting the computer. Select from the following settings:

HDD -> FDD -> CD-ROM -> LAN	The computer looks for bootable files in the following order: HDD, diskette drive, CD-ROM and LAN. (Default)
---	--

FDD -> HDD -> CD-ROM -> LAN	The computer looks for bootable files in the following order: diskette drive, HDD, CD-ROM and LAN.
---	--

HDD -> CD-ROM -> LAN -> FDD	The computer looks for bootable files in the following order: HDD, CD-ROM, LAN and diskette drive.
---	--

FDD -> CD-ROM -> LAN -> HDD	The computer looks for bootable files in the following order: diskette drive, CD-ROM, LAN and HDD.
---	--

CD-ROM -> LAN -> HDD -> FDD	The computer looks for bootable files in the following order: CD-ROM, LAN, HDD, diskette drive.
---	---

CD-ROM -> LAN -> FDD -> HDD	The computer looks for bootable files in the following order: CD-ROM, LAN, diskette drive and HDD.
---	--

You can override the settings and manually select a boot device by pressing one of the following keys while the computer is booting:

U	Selects the USB diskette drive.
----------	---------------------------------

N	Selects the Network.
----------	----------------------

1	Selects the primary HDD.
----------	--------------------------

P	Selects the PC card HDD.
----------	--------------------------

C	Selects the CD-ROM*.
----------	----------------------

* In this computer, CD-ROM refers to the Fixed optical media drive.



PC card HDD boot is supported only by slot 0 on the computer. Support is guaranteed only for TOSHIBA PC card HDDs.

When you assign a PC card HDD top priority, "PC" is not displayed. However, the PC card HDD takes the position of HDD in the Boot Priority Options list above.

To change the boot drive, follow the steps below.

1. Hold down **F12** and boot the computer.
2. The following menu will be displayed with the following icons: Built-in HDD, CD-ROM, FDD, Network (LAN), PC (ATA) card boot.



A bar will appear only under the selected device.

3. Use the left/right cursor keys to highlight the boot device you want and press **Enter**.



If a supervisor password is set, the menu above does not appear when you use the user password to start the computer.

The selection method above does not change the boot priority settings in HW Setup.

If you press a key other than one of those above or if the selected device is not installed, the system will boot according to the current setting in HW Setup.

Support of PC (ATA) card boot is guaranteed only for TOSHIBA PC card HDDs.

A PC (ATA) card takes the position of HDD in the Boot Priority Options list.

HDD Priority Options

If more than one HDD is installed in the computer, this option lets you set the priority for HDD detection. If the first detected HDD has a boot command, the system will boot from the HDD.

Built-in HDD -> HDDs are searched for a boot command in the following order: the built-in HDD, and the PC Card. (Default)

PC Card -> HDDs are searched for a boot command in the following order: the built-in HDD and the PC Card.
Built-in HDD



If a boot command is not found on the first detected HDD, the system will not boot from the other HDD. It will search the next device in the boot priority for a boot command.

Network Boot Protocol

This feature sets the protocol to remotely boot from the network.

[PXE]	Sets PXE as the protocol. (Default)
[RPL]	Sets RPL as the protocol.



The Wake-up on LAN function consumes power even when the system is off. Leave the universal AC adaptor connected while using this feature.

Keyboard

Wake-up on Keyboard

When this feature is enabled and the computer is in Standby mode, you can turn on the computer by pressing any key. It is effective only for the internal keyboard and only when the computer is in standby mode.

Enabled	Enables the Wake-up on Keyboard.
Disabled	Disables the Wake-up on Keyboard. (Default)

USB

USB KB/Mouse Legacy Emulation

Use this option to enable or disable USB KB/Mouse Legacy Emulation. If your operating system does not support USB, you can still use a USB mouse and keyboard by setting the **USB KB/Mouse Legacy Emulation** item to **Enabled**.

Enabled	Enables the USB KB/Mouse Legacy Emulation. (Default)
Disabled	Disables the USB KB/Mouse Legacy Emulation.

USB-FDD Legacy Emulation

Use this option to enable or disable USB-FDD Legacy Emulation.

Enabled	Enables the USB-FDD Legacy Emulation. (Default)
Disabled	Disables the USB-FDD Legacy Emulation.

LAN

Built-in LAN

This feature enables or disables the Built-in LAN.

Enabled	Enables Built-in LAN functions. (Default)
Disabled	Disables Built-in LAN functions.

Supervisor password

Refer to the readme file of the Supervisor Password Utility for instructions on setting the Supervisor Password.

The path to the readme file is **C:\Program Files\TOSHIBA\Windows Utilities\SVPWTool**. In the **SVPWTool** directory, open the **readme.htm** file.

Optional Devices

Optional devices can expand the computer's capabilities and its versatility. This Chapter describes connection or installation of the following devices, which are available from your TOSHIBA dealer:

Cards/memory

- PC cards
- Memory expansion

Power devices

- Battery pack
- Universal AC adaptor

Peripheral devices

- USB diskette drive
- External monitor
- Parallel printer

Other

- Security lock

PC cards

The computer is equipped with a PC card expansion slot that can accommodate one 5 mm Type II card. Any PC card that meets industry standards (manufactured by TOSHIBA or other vendor) can be installed. The slot supports 16-bit PC cards, including PC card 16's multifunction card and CardBus PC cards.

CardBus supports the new standard of 32-bit PC cards. The bus provides superior performance for the greater demands of multimedia data transmission.

Inserting a PC card

The PC card connector is located on the left side of the computer.

Windows' hot-install feature lets you install a PC card while the computer's power is on.



Do not insert a PC card while the computer is in standby or hibernation mode. Some cards might not work properly.

An HDD or CD-ROM connected to a 16-bit PC card, might affect the performance of the computer's sound system and data transmission, including slower transmission speeds and dialling errors.

To insert a PC card, follow the steps below.

1. Insert the PC card.
2. Press gently to ensure a firm connection.

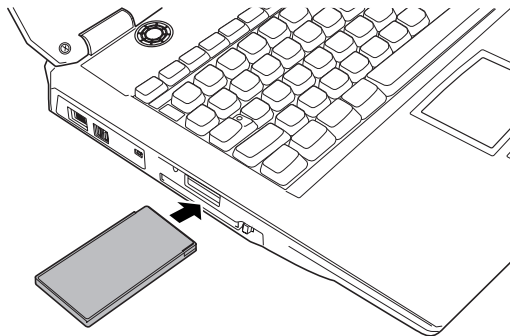

Inserting the PC card

3. Check the configuration in the HW Setup window to make sure it is appropriate for your card.

After installing the card, refer to the card's documentation and check the configuration in Windows to make sure it is appropriate for your card.

Removing a PC card

To remove the PC card, follow the steps below.

1. Click the **Safety Remove Hardware** icon on the System Tray.
2. Click **PC card**.
3. Press the PC card eject button to extend it.
4. Press the extended eject button to pop the card out slightly.
5. Pinch the PC card and remove it.

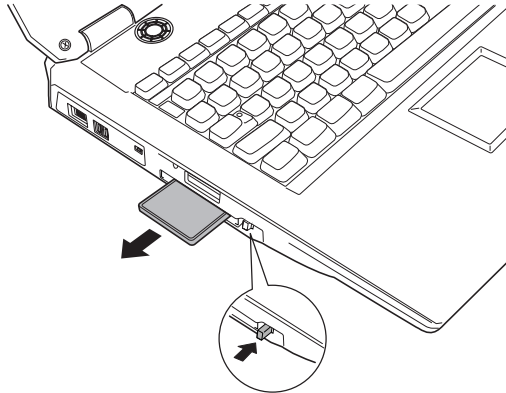

Removing the PC card

Memory

This computer is equipped with two memory module sockets beneath the keyboard. You can increase the amount of RAM by installing an additional memory or replacing default memories with additional memories. This section describes how to install and remove a memory module.



Refer to General Precautions for the attention when keyboard brace is removed.

Use only memory modules approved by TOSHIBA.

Do not try to install or remove a memory module under the following conditions. You can damage the computer and the module. Also, data will be lost.

- a. The computer is turned on.*
- b. The computer was shut down using the Stand by mode or Hibernation mode.*



Place a mat beneath the computer to prevent making a scratch on the lid when replacing the memory module. Avoid the mat that generates static electricity.

Use a point size 0 Phillips screwdriver to remove and fasten screws. Use of an incorrect screwdriver can damage the screw heads.

Installing a memory module

To install a memory module, make sure the computer is in boot mode then:

1. Turn the computer off in boot mode. Refer to the *Turning off the power* section in Chapter 3.
2. Remove all cables connected to the computer.
3. Turn the computer upside down and remove the battery pack (refer to Chapter 6, *Power and Power-Up Modes*.)
4. Slide the display latch on the front of the computer to the right and open the display panel.
5. Insert your fingernail or a thin object under the rim of the keyboard brace and lift out the brace.

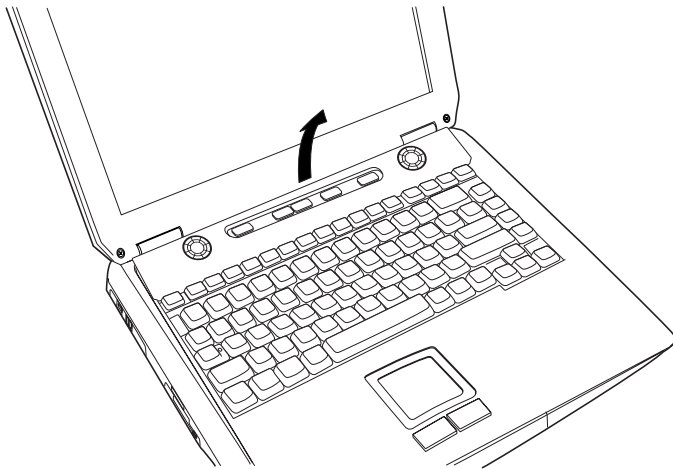

Removing the keyboard brace

6. Remove two screws securing the keyboard and one screw securing the metal brace. Lift off the metal brace.



Use a point size 0 Phillips screwdriver.

- Lift up the back of the keyboard, rotate it toward you and lay in face down on the palm rest.



When you move the keyboard forward, do not touch the keys. Doing so could cause misalignment. Hold the keyboard by the sides and lay it gently on the palm rest.

The keyboard is connected to the computer by a ribbon cable. Be careful not to apply tension to this cable when you lift up the keyboard. Do not try to disconnect this cable.

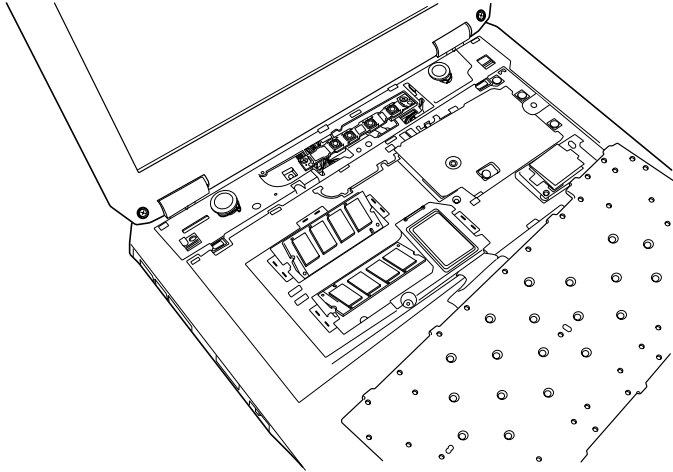

Removing three screws and one metal brace, and rotate the keyboard

- Lift into the left the insulation sheet covering the memory module and secure the sheet with tape to keep it out of your way.



Do not touch the connectors on the memory module or on the computer. Debris on the connectors may cause memory access problems.



The slot A is reserved for main memory. Use the slot B for expanded memory. If only one card is installed, use the slot A.

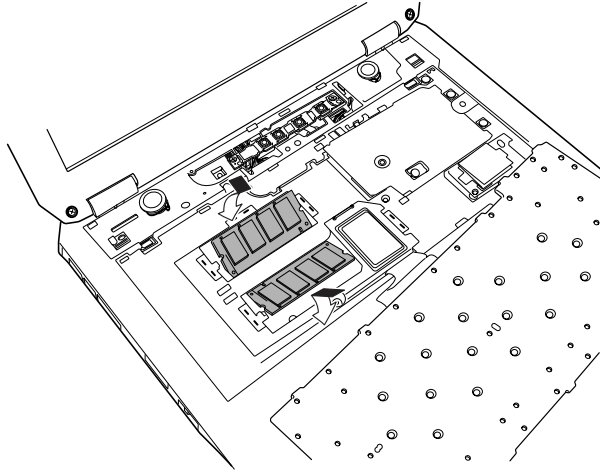

Lifting into the left the insulation sheet.

9. Insert a new module in the socket and push it down so it lies flat and is secured by two latches on either side.

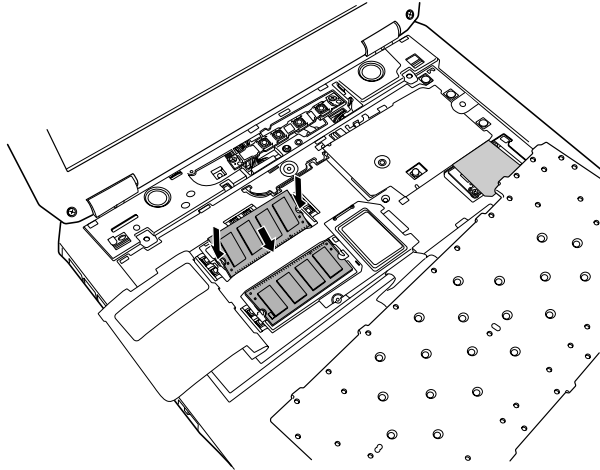

Installing the memory module.

10. Seat the insulation sheet to cover the module.



Be sure to check that the insulation sheet is returned to the original position to cover the memory module.

11. Insert tabs on the front of the keyboard into corresponding notches on the computer and seat the keyboard.



When seating the keyboard, be sure to fit the flexible printed circuit board under the palm rest if the flat cable was pulled out while you were removing the keyboard.

12. Two screws secure the keyboard and one screw secures the metal brace.



Be sure to use all two screws removed in step 6. Make sure no screw was dropped into the computer. Make sure all foreign matter, such as the tape applied in step 9 is removed.

13. Seat the keyboard brace and press to secure latches.
14. Install the battery pack. Refer to *Replacing the battery pack* section in Chapter 6, *Power and Power-up Modes*, for details.
15. Turn the power on and make sure the added memory is recognized. Open System Properties in the Control Panel and click the General tab.

Removing memory module

To remove the memory module, make sure the computer is in boot mode then:

1. Turn the computer off and remove all cables connected to the computer.
2. Turn the computer upside down and remove the battery pack (refer to Chapter 6, *Power and Power-Up Modes*.)
3. Slide the display latch on the front of the computer to the right and open the display panel.
4. Follow steps 5 through 8 in Installing memory module to access the memory module.
5. Push the latches to the outside to release the module. A spring will force one end of the module up.
6. Grasp the sides of the module and pull it out, then replace the insulator.



If you use the computer for a long time, the memory modules and the circuits locating close to the memory modules will become hot. In this case, let them cool to room temperature before you replace them. Or you will get burnt if you touch any of them.

Do not touch the connectors on the memory module or on the computer. Debris on the connectors may cause memory access problems.

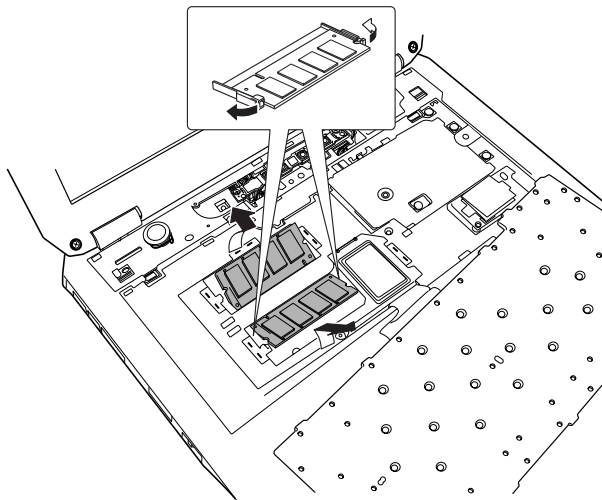

Removing the memory module

7. Rotate the keyboard back into place and secure the keyboard brace as described in the previous section.
8. Turn the computer upside down and replace the battery pack.

Battery pack

You can increase the portability of the computer with additional battery packs. If you're away from an AC power source and your battery runs low, you can replace it with a freshly charged battery. Refer to Chapter 6, *Power and Power-Up Modes*.

Universal AC adaptor

If you frequently transport the computer between different sites such as your home and office, purchasing an AC adaptor for each location will reduce the weight and bulk of your carrying load.

USB diskette drive

The 3 ½" external diskette drive module can be connected to the USB port. For details on connecting the 3 ½" external diskette drive module, refer to Chapter 4, *Operating Basics*.

External monitor

An external analog monitor can be connected to the external monitor port on the computer. The computer supports VGA and Super VGA video modes. To connect a monitor, follow the steps below.

1. Turn the computer off.
2. Connect the monitor to the external monitor port.
3. Turn the monitor's power on.
4. Turn the computer on.

When you turn on the power, the Windows Bootup screen (Windows Logo) appears on the display device that is set as the **power on Display** in HW Setup (Refer to Chapter 7, *HW Setup and Passwords*, for more information).

However, the Windows Desktop appears on a display device that you used last time to shut down your PC, if the display device exists when you turn on the power.

To change the display settings, press **Fn + F5**. If you disconnect the monitor before you turn the computer off, be sure to press **Fn + F5** to switch to the internal display. Refer to Chapter 5, *The Keyboard*, for details on using hot keys to change the display setting.

Parallel printer

You can connect any standard Centronics-compatible parallel printer to your computer. All you need is an IBM PC™ parallel printer cable. Your dealer can supply one or you can purchase one at most computer stores. The cable's connectors are designed so that it is impossible for you to connect them incorrectly. To connect a printer, follow these steps:

1. Turn off the computer.
2. Insert one end of the cable into the computer's parallel port.
3. Tighten the screws that fasten the cable connector to the computer's parallel port.
4. Insert the other end of the cable into the printer's parallel connector.
5. Fasten the connector to the printer with the clips on the parallel port.
6. Turn on the printer.
7. Turn on the computer.
8. Start the HW Setup program. Refer to Chapter 7, *HW Setup and Passwords*.
9. Select the **Parallel/Printer** tab from the **TOSHIBA HW Setup** window.
10. Set the **Parallel Port Mode** and press **OK**.
11. Choose **Reboot** for the change to take effect.
12. Select the printer in Windows Add Print Wizard. To access the **Add Print Wizard** utility, click **Start**, point to **Settings**, click **Printers** and double click the **Add Printer** icon.

Security lock

A security lock enables you to anchor your computer to a desk or other heavy object to help prevent unauthorized removal of the computer.

Attach one end of a cable to the desk and the other end to the security lock slot on the back side of the computer.



The Security Lock Slot is between Cooling Vent. After using this computer, the Security Lock Slot is hot because of the exhaust heat from the Cooling Vent. There is a possibility of getting burnt when the Security Lock Slot is touched at this time. Therefore, be careful enough work after it is confirmed that heat is cold enough after the computer is used.

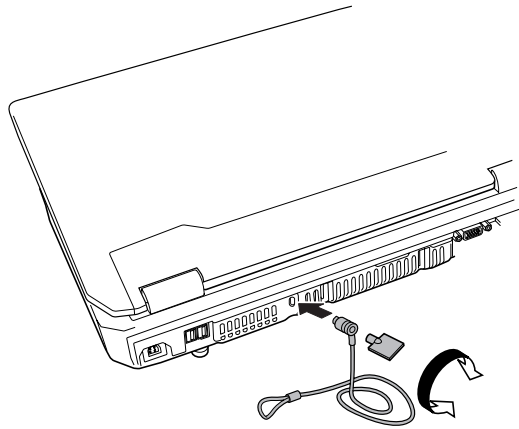

Security lock

Troubleshooting

TOSHIBA designed the computer for durability. However, should problems occur, following the procedures in this Chapter can help to determine the cause.

All readers should become familiar with this chapter. Knowing what might go wrong can help prevent problems from occurring.

Problem solving process

Resolving problems will be much easier if you observe the following guidelines:

- Stop immediately when you recognise a problem exists. Further action may result in data loss or damage. You may destroy valuable problem-related information that can help solve the problem.
- Observe what is happening. Write down what the system is doing and what actions you performed immediately before the problem occurred. If you have a printer attached, print a copy of the screen using **PrtSc SysReq**.

The questions and procedures offered in this Chapter are meant as a guide, they are not definitive problem solving techniques. Many problems can be solved simply, but a few may require help from your dealer. If you find you need to consult your dealer or others, be prepared to describe the problem in as much detail as possible.

Preliminary checklist

Consider the simplest solution first. The items in this checklist are easy to fix and yet can cause what appears to be a serious problem.

- Make sure you turn on all peripheral devices before you turn on the computer. This includes your printer and any other external device you are using.
- Before you attach an external device, turn the computer off. When you turn the computer back on it recognises the new device.
- Make sure all options are set properly in the setup program.
- Check all cables. Are they correctly and firmly attached? Loose cables can cause signal errors.
- Inspect all connecting cables for loose wires and all connectors for loose pins.
- Check that your diskette, CD/DVD-ROM is correctly inserted and that the diskette's write protect tab is correctly set.

Make notes of your observations and keep them in a permanent error log. This will help you describe your problems to your dealer. If a problem recurs, the log will help you identify the problem faster.

Analysing the problem

Sometimes the system gives clues that can help you identify why it is malfunctioning. Keep the following questions in mind:

- Which part of the system is not operating properly: keyboard, diskette drives, hard disk drive, optical media drive, display. Each device produces different symptoms.
- Is the operating system configuration set properly? Check the configuration options.
- What appears on the display screen? Does it display any messages or random characters? Print a copy of the screen if you have a printer attached. Look up the messages in the software and operating system documentation. Check that all connecting cables are correctly and firmly attached. Loose cables can cause erroneous or intermittent signals.
- Do any indicators light? Which ones? What colour are they? Do they stay on or blink? Write down what you see.
- Do you hear any beeps? How many? Are they long or short? Are they high pitched or low? Is the computer making any unusual noises? Write down what you hear.

Record your observations so you can describe them to your dealer.

Software

The problems may be caused by your software or disk (disc). If you cannot load a software package, the media may be damaged or the program might be corrupted. Try loading another copy of the software.

If an error message appears while you are using a software package, check the software documentation. These documents usually include a problem solving section or a summary of error messages.

Next, check any error messages in the OS documentation.

Hardware

If you cannot find a software problem, check your hardware. First run through the items in the preliminary checklist above. If you still cannot correct the problem, try to identify the source. The next section provides checklists for individual components and peripherals.

Hardware and system checklist

This section discusses problems caused by your computer's hardware or attached peripherals. Basic problems may occur in the following areas:

- | | |
|-----------------------------|-----------------------|
| ■ System start-up | ■ PC card |
| ■ Self Test | ■ |
| ■ Power | ■ Pointing device |
| ■ Battery | ■ USB |
| ■ Password | ■ Memory expansion |
| ■ Keyboard | ■ Sound system |
| ■ LCD panel | ■ Monitor |
| ■ Hard disk drive | ■ Modem |
| ■ CD-RW/DVD-ROM drive | ■ Standby/Hibernation |
| ■ DVD-R/-RW drive | ■ LAN |
| ■ Diskette drive (optional) | ■ Real Time Clock |
| | ■ Printer |

System start-up

When the computer does not start properly, check the following items:

- Self Test
- Power Sources
- Power-on Password

Self test

When the computer starts up, the self test will be run automatically, and the following will be displayed:



In Touch with Tomorrow
TOSHIBA

This message remains on the screen for a few seconds.

If the self test is successful, the computer tries to load the operating system, depending on how the Boot Priority is set in the TOSHIBA HW Setup program.

If any of the following conditions are present, the self test failed:

- The computer stops and does not proceed to display information or messages except the TOSHIBA logo.
- Random characters appear on the screen, and the system does not function normally.
- The screen displays an error message.

Turn off the computer and check all cable connections as well as PC card and memory module connections. If the test fails again, contact your dealer.

Power

When the computer is not plugged into an AC outlet, the battery pack is the primary power source. However, your computer has a number of other power resources, including intelligent power supply, Real Time Clock battery. These resources are interrelated and any one could affect apparent power problems. This section provides check lists for AC power and the main battery. If you cannot resolve a problem after following them, the cause could lie with another power resource. In such case, contact your dealer.

Overheating power down

If the computer's internal temperature becomes too high, the computer will automatically enter Hibernation or Resume mode and shut down.

Problem	Procedure
Computer shuts down and DC IN 15V indicator blinks orange	<p>Leave the computer off until the DC IN 15V indicator stops blinking.</p> <p>It is recommended to leave the computer off until the its interior reaches room temperature even though the DC IN 15V indicator stops blinking.</p> <p>If the computer has reached room temperature and still does not start, or if it starts but shuts down quickly, contact your dealer.</p>
Computer shuts down and its DC IN 15V indicator is flashing green	<p>Indicates a problem with the heat dispersal system. Please contact your dealer.</p>

AC power

If you have trouble turning on the computer with the AC adaptor connected, check the **DC IN 15V** indicator. Refer to Chapter 6, *Power and Power-Up Modes*, for more information.

Problem	Procedure
AC adaptor doesn't power the computer (DC IN 15V indicator does not glow green)	<p>Check the connections. Make sure the cord is firmly connected to the computer and a power outlet.</p> <p>Check the condition of the cord and terminals. If the cord is frayed or damaged, replace it. If the terminals are soiled, wipe them with cotton or a clean cloth.</p> <p>If the AC adaptor still does not power the computer, contact your dealer.</p>

Battery

If you suspect a problem with the battery, check the **DC IN 15V** indicator as well as the **Battery** indicator. For information on indicators and battery operation see Chapter 6, *Power and Power-Up Modes*.

Problem	Procedure
Battery doesn't power the computer	The battery may be discharged. Connect the AC adaptor to charge the battery.
Battery doesn't charge when the AC adaptor is attached (Battery indicator does not glow orange.)	<p>If the battery is completely discharged, it will not begin charging at once. Wait a few minutes.</p> <p>If the battery still does not charge, make sure the outlet is supplying power. Plug in an appliance and see if it works. If it doesn't, try another power source.</p> <p>Check whether the battery is hot or cold. If the battery is too hot or too cold, it will not charge properly. Let it reach room temperature.</p> <p>Unplug the AC adaptor and remove the battery to make sure the terminals are clean. If necessary wipe them with a soft dry cloth dipped in alcohol.</p> <p>Connect the AC adaptor and replace the battery.</p> <p>Make sure the battery is securely seated.</p> <p>Check the Battery indicator. If it does not glow, let the computer charge the battery for at least 20 minutes. If the Battery indicator glows after 20 minutes, let the battery continue to charge at least another 20 minutes before turning on the computer.</p> <p>If the indicator still does not glow, the battery may be at the end of its operating life. Replace it.</p> <p>If you do not think the battery is at the end of its operating life, see your dealer.</p>
Battery doesn't power the computer as long as expected	<p>If you frequently recharge a partially charged battery, the battery might not charge to its full potential. Fully discharge the battery, then try to charge it again.</p> <p>Check the power consumption settings in TOSHIBA Power Saver. Consider using a power saving mode.</p>

Password



For information on setting and using a password, refer to Chapter 7, *HW Setup and Passwords*.

Problem	Procedure
Cannot enter or forgot password	Contact your dealer.

Keyboard

Keyboard problems can be caused by your setup configuration. For more information refer to Chapter 5, *The Keyboard*, and Chapter 7, *HW Setup and Passwords*.

Problem	Procedure
Some letter keys produce numbers	Check that the numeric keypad overlay is not selected. Press Fn + F10 and try typing again.
Output to screen is garbled	Make sure the software you are using is not remapping the keyboard. Remapping involves reassigning the meaning of each key. See your software's documentation. If you are still unable to use the keyboard, consult your dealer.
Key-top comes off	Follow the figures below to attach Enter, Back Space, Shift or Space key when they come off. For the other keys, press the key-top until you hear a click after replacing it to the right position.

The way to replace the key-top

Press the key-top until you hear a click after removing a metal spring from the key-top, hooking it to projecting parts and aligning the centre of the key-top.

Enter, Back Space, Shift and Space key

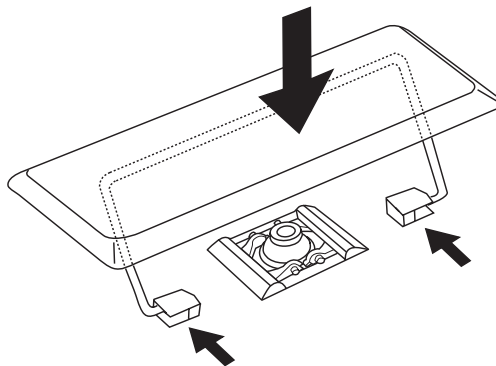
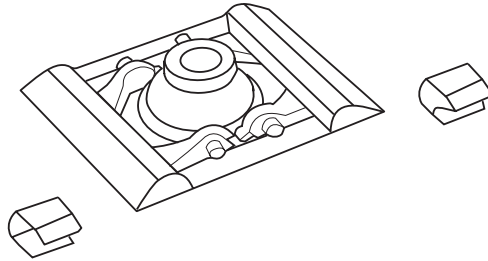

Follow the steps below when a plastic spring is out of place together with a key-top.

1. Remove the plastic spring from the key-top.

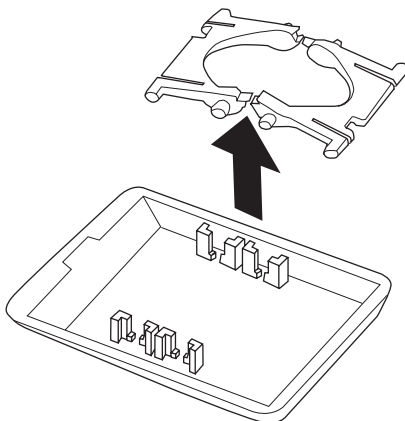

2. Attach the plastic spring to the keyboard with its flat face downward after confirming the direction.

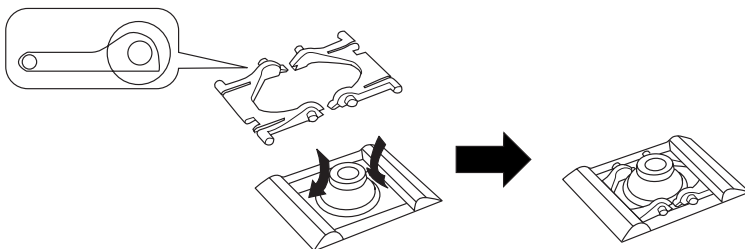

3. Press from the upside until you hear a click after replacing the key-top to the right position.

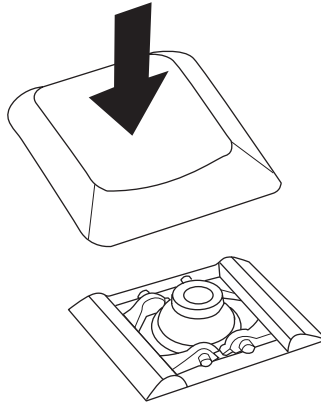

LCD panel

Apparent LCD problems may be related to the computer's setup. Refer to Chapter 7, *HW Setup and Passwords* for more information.

Problem	Procedure
No display	Press hot keys Fn + F5 to change the display priority, to make sure it is not set for an external monitor.
Markings appear on the LCD.	They might have come from contact with the keyboard, Touch Pad. Try wiping the LCD gently with a clean dry cloth. If markings remain, use LCD cleaner. Be sure to let the LCD dry before closing it.
Problems above remain unresolved or other problems occur	Refer to your software's documentation to determine if the software is causing the difficulty. Contact your dealer if the problems continue.

Hard disk drive

Problem	Procedure
Computer does not boot from hard disk drive	<p>Check if a diskette is in the diskette drive or a CD-ROM is in the optical media drive. Remove any diskette and/or CD-ROM and check Boot priority. Refer to the <i>Boot Priority</i> section in Chapter 7, <i>HW Setup and Passwords</i>.</p> <p>There may be a problem with your operating system files. Refer to your OS documentation.</p>
Slow performance	<p>Your files may be fragmented. Run SCANDISK and defragmenter to check the condition of your files and disk. Refer to your OS documentation or online HELP for information on running SCANDISK and the defragmenter.</p> <p>As a last resort, reformat the hard disk. Then, reload the operating system and other files.</p> <p>If problems persist, contact your dealer.</p>

CD-RW/DVD-ROM drive

For more information, refer to Chapter 4, *Operating Basics*.

Problem	Procedure
You cannot access a CD/DVD in the drive	<p>Make sure the drive's drawer is securely closed. Press gently until it clicks into place.</p> <p>Open the drawer and make sure the CD/DVD is properly seated. It should lie flat with the label facing up.</p> <p>A foreign object in the drawer could block laser light from reading the CD/DVD. Make sure there is no obstruction. Remove any foreign object.</p> <p>Check whether the CD/DVD is dirty. If it is, wipe it with a clean cloth dipped in water or a neutral cleaner. See the <i>Media care</i> section in Chapter 4 for details on cleaning.</p>

Problem	Procedure
Some CD/DVDs run correctly, but others do not	<p>The software or hardware configuration may be causing a problem. Make sure the hardware configuration matches your software's needs. Check the CD/DVD's documentation.</p> <p>Check the type of CD/DVD you are using. The drive supports:</p> <p>DVD-ROM: DVD-ROM, DVD-Video</p> <p>CD-ROM: CD-DA, CD-Text, Photo CD (single/multi-session), CD-ROM Mode 1, Mode 2, CD-ROM XA Mode 2 (Form1, Form2), Enhanced CD (CD-EXTRA), CD-G (Audio CD only), Addressing Method 2</p> <p>Check the region code on the DVD. It must match that on the CD-RW/DVD-ROM drive. Region codes are listed in the <i>Optical media drives</i> section in Chapter 2, <i>The Grand Tour</i>.</p>
Cannot write correctly	<p>If you have trouble writing, make sure you are observing the following precautions:</p> <ul style="list-style-type: none">■ Use only media recommended by TOSHIBA.■ Do not use the mouse or keyboard during writing.■ Use only the software supplied with the computer for recording.■ Do not run or start other software during writing.■ Do not jar the computer during writing.■ Do not connect/ disconnect external devices or install/remove internal cards during writing. <p>If problems persist, contact your dealer.</p>

DVD-R/-RW drive

For more information, refer to Chapter 4, *Operating Basics*.

Problem	Procedure
You cannot access a CD/DVD in the drive	<p>Make sure the drive's drawer is securely closed. Press gently until it clicks into place.</p> <p>Open the drawer and make sure the CD/DVD is properly seated. It should lie flat with the label facing up.</p> <p>A foreign object in the drawer could block laser light from reading the CD/DVD. Make sure there is no obstruction. Remove any foreign object.</p> <p>Check whether the CD/DVD is dirty. If it is, wipe it with a clean cloth dipped in water or a neutral cleaner. See the <i>Media care</i> section in Chapter 4 for details on cleaning.</p>
Some CD/DVDs run correctly, but others do not	<p>The software or hardware configuration may be causing a problem. Make sure the hardware configuration matches your software's needs. Check the CD/DVD's documentation.</p> <p>Check the type of CD/DVD you are using. The drive supports:</p> <p>DVD-ROM: DVD-ROM, DVD-Video</p> <p>CD-ROM: CD-DA, CD-Text, Photo CD (single/multi-session), CD-ROM Mode 1, Mode 2, CD-ROM XA Mode 2 (Form1, Form2), Enhanced CD (CD-EXTRA), CD-G (Audio CD only), Addressing Method 2</p> <p>Check the region code on the DVD. It must match that on the DVD-R/RW drive. Region codes are listed in the <i>Optical media</i> section in Chapter 2, <i>The Grand Tour</i>.</p>

Cannot write correctly

If you have trouble writing, make sure you are observing the following precautions:

- Use only media recommended by TOSHIBA.
- Do not use the mouse or keyboard during writing.
- Use only the software supplied with the computer for recording.
- Do not run or start other software during writing.
- Do not jar the computer during writing.
- Do not connect/ disconnect external devices or install/remove internal cards during writing.
- If problems persist, contact your dealer.

Diskette drive

For more information, refer to Chapter 4, *Operating Basics*.

Problem	Procedure
Drive does not operate	There may be a faulty cable connection. Check the connection to the computer and to the drive.
Some programs run correctly but others do not	The software or hardware configuration may be causing a problem. Make sure the hardware configuration matches your software needs.
You cannot access the external 3 1/2" diskette drive	Try another diskette. If you can access the diskette, the original diskette (not the drive) is probably causing the problem. If problems persist, contact your dealer.

PC card

Refer also to Chapter 8, *Optional Devices*.

Problem	Procedure
PC card error occurs	<p>Reseat the PC card to make sure it is firmly connected.</p> <p>Make sure the connection between the external device and the card is firm.</p> <p>Check the card's documentation.</p> <p>If problems persist, contact your dealer.</p>

Pointing device

If you are using a USB mouse, also refer to the *USB* section in this Chapter and to your mouse documentation.

Touch pad

Problem	Procedure
On-screen pointer does not respond to pad operation	<p>The system might be busy. If the pointer is shaped as an hourglass, wait for it to resume its normal shape and try again to move it.</p>
Double-tapping does not work	<p>Try changing the double-click speed setting in the mouse control utility.</p> <ol style="list-style-type: none"> 1. Open the Control Panel, select the Mouse icon and press Enter. 2. Click the Buttons tab. 3. Set the double-click speed as instructed and click OK.
The mouse pointer moves too fast or too slow	<p>Try changing the speed setting in the mouse control utility.</p> <ol style="list-style-type: none"> 1. Open the Control Panel, select the Mouse icon and press Enter. 2. Click the Pointer Options tab. 3. Set the speed as instructed and click OK. <p>If problems persist, contact your dealer.</p>

USB mouse

Problem	Procedure
On-screen pointer does not respond to mouse operation	<p>The system might be busy. If the pointer is shaped as an hourglass, wait for it to resume its normal shape and try again to move it.</p> <p>Make sure the mouse is properly connected to the USB port.</p>
Double-clicking does not work	<p>Try changing the double-click speed setting in the mouse control utility.</p> <ol style="list-style-type: none"> 1. Open the Control Panel, select the Mouse icon and press Enter. 2. Click the Buttons tab. 3. Set the double-click speed as instructed and click OK.
The mouse pointer moves too fast or too slow	<p>Try changing the speed setting in the mouse control utility.</p> <ol style="list-style-type: none"> 1. Open the Control Panel, select the Mouse icon and press Enter. 2. Click the Pointer Options tab. 3. Set the speed as instructed and click OK.
The mouse pointer moves erratically	<p>The mouse might be dirty. Refer to your mouse documentations for instructions on cleaning.</p> <p>If problems persist, contact your dealer.</p>

USB

Refer also to your USB device's documentation.

Problem	Procedure
USB device does not work	<p>Check for a firm cable connection between the USB ports on the computer and the USB device.</p> <p>Make sure the USB device drivers are properly installed. Refer to your Windows XP documentation for information on checking the drivers.</p> <p>If you are using an operating system that does not support USB, you can still use a USB mouse and/or USB keyboard. If these devices do not work, make sure the USB KB/Mouse Legacy Emulation item in HW Setup is set to Enabled.</p> <p>If problems persist, contact your dealer.</p>

Memory expansion

Refer also to Chapter 8, *Optional Devices*, for information on installing memory modules.

Problem	Procedure
Beep sounds. (If slot A two beeps, If slot B three beeps, If both, two and three beeps.)	<p>Make sure the memory module installed in the expansion slot is compatible with the computer.</p> <p>If an incompatible module has been installed, follow the steps below.</p> <ol style="list-style-type: none"> 1. Turn off the power. 2. Disconnect the universal AC adaptor and all peripheral devices. 3. Remove the battery. 4. Remove the memory module. 5. Replace the battery and/or connect the AC adaptor. 6. Turn on the power. <p>If problems persist, contact your dealer.</p>

Sound system

Refer also to documentation for your audio devices.

Problem	Procedure
No sound is heard	Adjust the volume control dial. Check the software volume settings. Make sure the headphone connection is secure. If problems persist, contact your dealer.

External Monitor

Refer also to Chapter 8, *Optional Devices*, and to your monitor's documentation.

Problem	Procedure
Monitor does not turn on	Make sure that the external monitor's power switch is on. Confirm that the external monitor's power cable is plugged into a working power outlet.
No display	Try adjusting the contrast and brightness controls on the external monitor. Press hot keys Fn + F5 to change the display priority and make sure it is not set for the internal display.
Display error occurs	Check that the cable connecting the external monitor to the computer is attached firmly. If problems persist, contact your dealer.

Modem

Problem	Procedure
Communication software can't initialise modem	Make sure the computer's internal modem settings are correct. Refer to <i>Phone and Modem Properties</i> in the Control Panel.
You can hear a dial tone but can't make a call	If the call is going through a PBX machine, make sure the communication application's tone dial detection feature is disabled.
You place a call, but a connection can't be made	Make sure the settings are correct in your communications application.
After making a call you can't hear a ring	Make sure the tone or pulse selection in your communications application is set correctly.
Communication is cut off unexpectedly	The computer will automatically cut off communication when connection with the carrier is not successful for a set time interval. Try lengthening this time interval.
A CONNECT display is quickly replaced by NO CARRIER	Check the error control setting in your communications application.
Character display becomes garbled during a communication	In data transmission, make sure the parity bit and stop bit settings correspond with those of the remote computer. Check the flow control and communication protocol.
You cannot receive an incoming call	Check the rings before auto answer setting in your communications application. If problems persist, contact your dealer.

Standby/Hibernation

Problem	Procedure
The system will not enter Standby/Hibernation	<p>Is Windows Media™ Player open? The system might not enter Standby/Hibernation, if Windows Media Player is either playing a selection or finished playing a selection. Close Windows Media Player before you select Standby/Hibernation.</p> <p>If problems persist, contact your dealer.</p>

LAN

Problem	Procedure
Cannot access LAN	<p>Check for a firm cable connection between the LAN jack and the LAN HUB.</p> <p>If problems persist, consult your LAN administrator.</p>

Real Time Clock

Problem	Procedure
The following message is displayed on the LCD: RTC battery is low or CMOS checksum is inconsistent. Press F1 key to set Date/Time.	<p>The battery for RTC is wearing. Set the date and time in BIOS setup with the following steps:</p> <ol style="list-style-type: none"> 1. Press F1 key. BIOS setup will boot up. 2. Set the date in System Date. 3. Set the time in System Time. 4. Press End key. Confirmation message will appear. 5. Press Y key. BIOS setup will terminate and the computer will be rebooted.

Printer

Refer also to the Parallel printer sections in Chapter 8, *Optional Devices*, and to the troubleshooting and other relevant sections in your printer and software documentation.

Problem	Procedure
Printer does not turn on.	Check that the printer is connected to an electric outlet. Make sure the outlet is supplying power by plugging in an appliance.
Computer/printer do not communicate	<p>Make sure the printer is turned on and is online (ready to use).</p> <p>Inspect the cable connecting the printer to the computer for damage. Make sure it is securely connected.</p> <p>A parallel printer connects to the parallel port. Make sure the port is configured correctly. Refer to Chapter 7, <i>HW Setup and passwords</i>.</p> <p>Make sure your software is configured to recognize the printer. Check your printer and software documentation.</p>
Printer error	<p>Check your printer documentation.</p> <p>If problems persist, contact your dealer.</p>

If you need further assistance

If you require any additional help using your computer or if you are having problems operating the computer, you may need to contact TOSHIBA for additional technical assistance.

Before you call

Some problems you experience may be related to software or the operating system, it is important to investigate other sources of assistance first. Before contacting TOSHIBA, try the following:

- Review troubleshooting sections in the documentation for software and peripheral devices.
- If a problem occurs when you are running software applications, consult the software documentation for troubleshooting suggestions. Call the software company's technical support for assistance.
- Consult the dealer you purchased your computer and/or software from. They are your best sources for current information and support.

Where to write

If you are still unable to solve the problem and suspect that it is hardware related, write to TOSHIBA at the location listed in the accompanying warranty booklet or visit www.toshiba-europe.com on the Internet.

Appendix A

Specifications

This appendix summarises the computer's technical specifications.

Physical Dimensions

Size	337 (w) x 298 (d) x40/46 (h) millimetres (not including parts that extend beyond the main body)
Weight	3.5 kilograms, configured with: 15"XGA-TFT, CD-RW/DVD-ROM drive, Modem, LAN Weight will vary with other configurations.

Environmental Requirements

Conditions	Ambient temperature	Relative humidity
Operating	5°C (41°F) to 30°C (86°F)	20% to 80%
Non-operating	-20°C (-4°F) to 55°C (131°F)	10% to 90%
Thermal Gradient	20°C per hour maximum	
Wet-bulb temperature	26°C maximum	
Conditions	Altitude (from sea level)	
Operating	-60 to 3,000 metres	
Non-operating	-60 to 10,000 metres <i>maximum</i>	

Power Requirements

AC adaptor	100-240 volts AC 50 or 60 hertz (cycles per second)
Computer	15 VDC 8.0 amperes

Built-in Modem

Network control unit (NCU)

Type of NCU	AA
Type of line	Telephone line (analogue only)
Type of dialling	Pulse Tone
Control command	AT commands EIA-578 commands
Monitor function	Computer's speaker

Communication specifications

Communication system	Data: Full duplex Fax: Half duplex
Communication protocol	Data ITU-T-Rec (Former CCITT) V.21/V.22/V.22bis/V.32/V.32bis/V.34/V.90 Bell 103/212A Fax ITU-T-Rec (Former CCITT) V.17/V.29/V.27ter/V.21 ch2
Communication speed	Data transmission and reception speed 300/1200/2400/4800/7200/9600/12000/14400/16800/19200/21600/24000/26400/28800/31200/33600 bps Data reception only with V.90 28000/29333/30666/32000/33333/34666/36000/37333/38666/40000/41333/42666/44000/45333/46666/48000/49333/50666/52000/53333/54666/56000 bps Fax 2400/4800/7200/9600/12000/14400 bps

Transmitting level	-10 dBm
Receiving level	-10 to -40 dBm
Input/output impedance	600 ohms \pm 30%
Error correcting	MNP class 4 and ITU-T V.42
Data compression	MNP class 5 and ITU-T V.42bis
Power supply	+3.3V (supplied by computer)

Certification

This product is approved for electrical safety and/or electromagnetic compatibility (EMC) by the following associations:

TÜV

DIN GOST TÜV

UL

CSA

FCC



TOSHIBA declares that this product complies with the following directives to be observed for CE marking. CE-Marking is the responsibility of TOSHIBA Europe GmbH, Hammfelddamm 8, 41460 Neuss, Germany.

93/68/EEC	CE marking directive
89/336/EEC	EMC directive
73/23/EEC	Low voltage directive
99/05/EEC	R&TTE Directive
EN 60950	Electrical safety
EN 55022	EMC / Radio disturbances
EN 50082-1 or EN55024	EMC / Immunity
EN61000-3-2,-3-3	Disturbances in supply systems

Appendix B

AC Power Cord and Connectors

The power cord's AC input plug must be compatible with the various international AC power outlets and the cord must meet the standards for the country/region in which it is used. All cords must meet the following specifications:

Length:	Minimum 2 metres
Wire size:	Minimum 0.75 mm ²
Current rating:	Minimum 2 Amperes
Voltage rating:	125 or 250 VAC (depending on country/region's power standards)

Certification agencies

U.S. and Canada:	UL listed and CSA certified No. 18 AWG, Type SVT or SPT-2 two conductor
Australia:	AS
Japan:	DENANHO
<i>Europe:</i>	
Austria:	OVE
Belgium:	CEBEC
Denmark:	DEMKO
Finland:	SETI
France:	UTE

Germany:	VDE
Italy:	IMQ
The Netherlands:	KEMA
Norway:	NEMKO
Sweden:	SEMKO
Switzerland:	SEV
United Kingdom:	BSI

In Europe, power cords must be VDE type, H05VVH2-F and two conductor.

For the United States and Canada, plug configuration must be a 2-15P (250 V) or 1-15P (125 V) as designated in the U.S. National Electrical code handbook and the Canadian Electrical Code Part II.

The following illustrations show the plug shapes for the U.S.A. and Canada, the United Kingdom, Australia and Europe.

USA and Canada

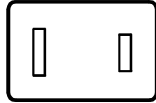

UL approved
CSA approved

United Kingdom

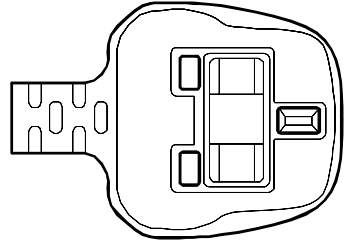

BS approved

Australia

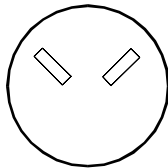

AS approved

Europe

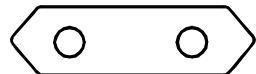

Approved by the
appropriate agency

Appendix C

Keyboard Layouts

Arabic



Belgian



Danish



French



German



Greek

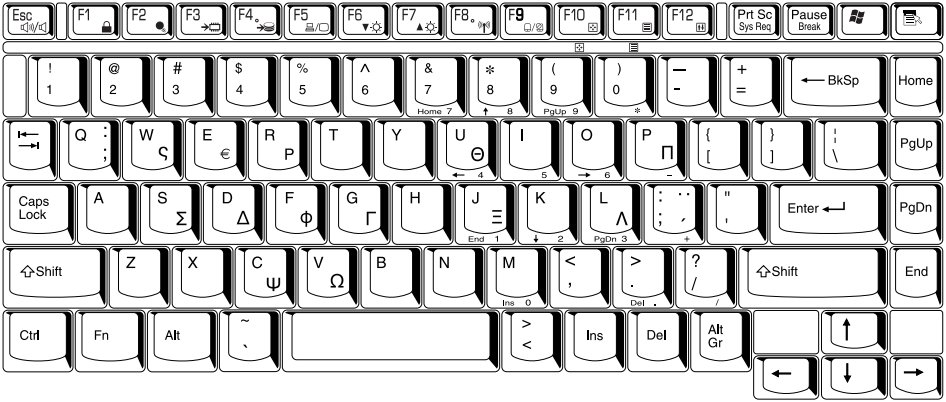

Hebrew



Italian



Norwegian

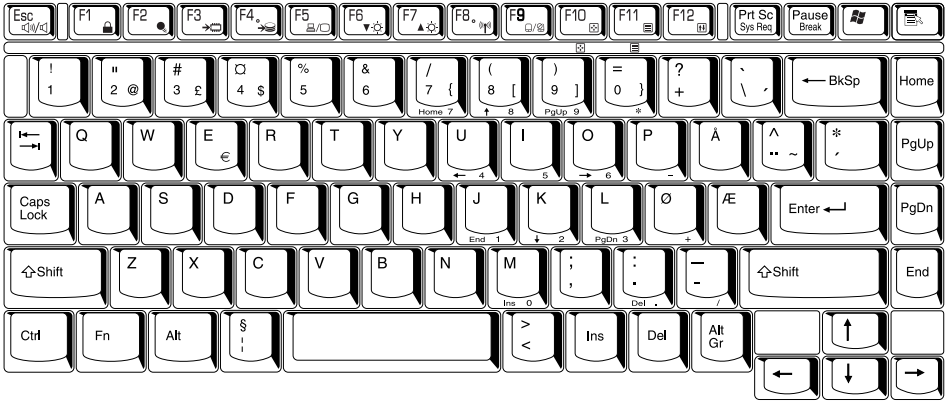

Polish

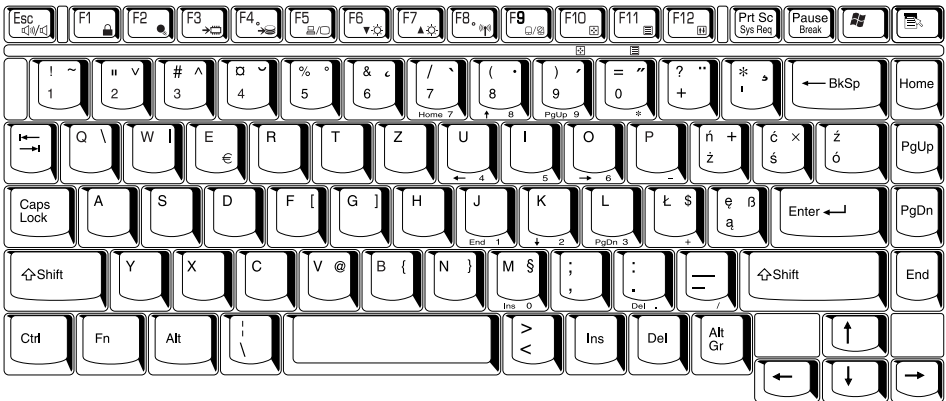

Portuguese



Russian



Spanish



Swedish



Swiss-German

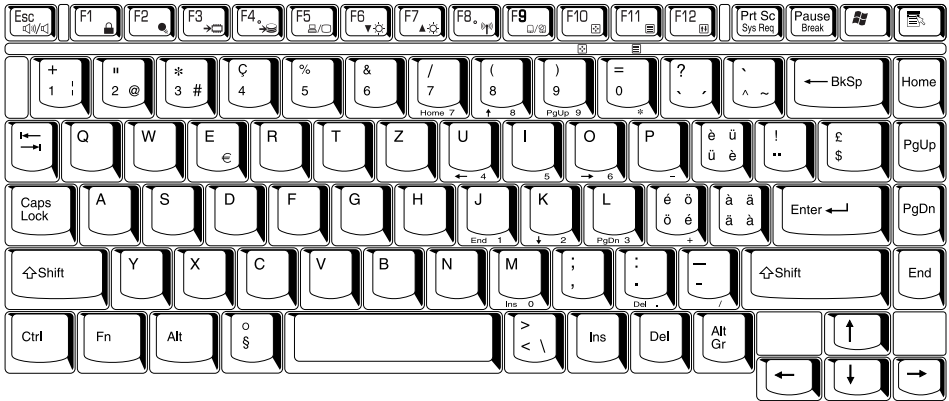

Turkish



UK English



US English

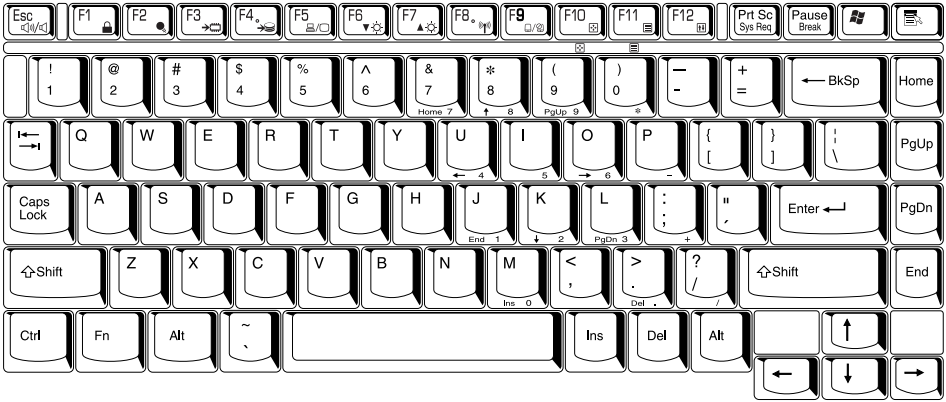

Display Controller and Modes

Display controller

The display controller interprets software commands into hardware commands that turn particular pels on or off.

The controller is an advanced Video Graphics Array (VGA) that provides Extended Graphics Array (XGA) support for the internal LCD and external monitors.

The 15.0" TFT LCD panel displays up to 1024 horizontal and 768 vertical pixels.

A high-resolution external monitor connected to the computer can display up to 2048 horizontal and 1536 vertical pixels at 16M colours

The display controller also controls the video mode, which uses industry standard rules to govern the screen resolution and the maximum number of colours that can be displayed on screen.

Software written for a given video mode will run on any computer that supports the mode.

The computer's display controller supports all VGA and SVGA modes, the most widely used industry standards.

Video modes

The computer supports video modes defined in the tables below. If your application offers a selection of mode numbers that do not match the numbers on the table, select a mode based on mode type, resolution, character matrix, number of colours and refresh rates. Also, if your software supports both graphics and text modes, the screen display may appear to operate faster using a text mode.

Table 1 Video modes (VGA)

Video Mode	Type	Resolution	Character matrix (pels)	LCD Colours	CRT Colours	Scanning frequency Vertical (Hz)
0, 1	VGA Text	40 x 25 Characters	8 x 8	16 of 256K	16 of 256K	70
2, 3	VGA Text	80 x 25 Characters	8 x 8	16 of 256K	16 of 256K	70
0*, 1*	VGA Text	40 x 25 Characters	8 x 14	16 of 256K	16 of 256K	70
2*, 3*	VGA Text	80 x 25 Characters	8 x 14	16 of 256K	16 of 256K	70
0+, 1+	VGA Text	40 x 25 Characters	9 x 16	16 of 256K	16 of 256K	70
2+, 3+	VGA Text	80 x 25 Characters	9 x 16	16 of 256K	16 of 256K	70
4, 5	VGA Grph	320 x 200 Pels	8 x 8	4 of 256K	4 of 256K	70
6	VGA Grph	640 x 200 Pels	8 x 8	2 of 256K	2 of 256K	70
7	VGA Text	80 x 25 Characters	9 x 14	Mono	Mono	70
7+	VGA Text	80 x 25 Characters	9 x 16	Mono	Mono	70
D	VGA Grph	320 x 200 Pels	8 x 8	16 of 256K	16 of 256K	70
E	VGA Grph	640 x 200 Pels	8 x 8	16 of 256K	16 of 256K	70
F	VGA Grph	640 x 350 Pels	8 x 14	Mono	Mono	70
10	VGA Grph	640 x 350 Pels	8 x 14	16 of 256K	16 of 256K	70
11	VGA Grph	640 x 480 Pels	8 x 16	2 of 256K	2 of 256K	60
12	VGA Grph	640 x 480 Pels	8 x 16	16 of 256K	16 of 256K	60
13	VGA Grph	320 x 200 Pels	8 x 8	256 of 256K	256 of 256K	70

Table 2 Video modes (XGA)

Resolution	LCD colours	CRT colours	Vertical frequency (Hz)
640 × 480	256/256K	256/256K	60 75 85 100
800 × 600	256/256K	256/256K	60 75 85 100
1024 × 768	256/256K	256/256K	60 75 85 100
1280 × 1024	256/256K (Virtual)	256/256K	60 75 85 100
1400 × 1050	256/256K (Virtual)	256/256K	60 75 85 100
1600 × 1200	256/256K (Virtual)	256/256K	60 75 85 100
1920 × 1440	256/256K (Virtual)	256/256K	60 75 85
2048 × 1536	256/256K (Virtual)	256/256K	60 75
640 × 480	64K/64K	64K/64K	60 75 85 100
800 × 600	64K/64K	64K/64K	60 75 85 100
1024 × 768	64K/64K	64K/64K	60 75 85 100
1280 × 1024	64K/64K (Virtual)	64K/64K	60 75 85 100

Resolution	LCD colours	CRT colours	Vertical frequency (Hz)
1400 × 1050	64K/64K (Virtual)	64K/64K	60 75 85
1600 × 1200	64K/64K (Virtual)	64K/64K	60 75 85 100
1920 × 1440	64K/64K (Virtual)	64K/64K	60 75 85
2048 × 1536	64K/64K (Virtual)	64K/64K	60 75
640 × 480	16M/16M	16M/16M	60 75 85 100
800 × 600	16M/16M	16M/16M	60 75 85 100
1024 × 768	16M/16M	16M/16M	60 75 85 100
1280 × 1024	16M/16M (Virtual)	16M/16M	60 75 85 100
1400 × 1050	16M/16M (Virtual)	16M/16M	60 75 85
1600 × 1200	16M/16M (Virtual)	16M/16M	60 75 85 100
1920 × 1440	16M/16M (Virtual)	16M/16M	60 75 85
2048 × 1536	16M/16M (Virtual)	16M/16M	60 75



Some SVGA modes are not supported at LCD+CRT simultaneous mode and LCD+CRT Multi Monitor mode.

Display Settings

1. You cannot activate the multi-monitor mode in the **Settings** tab of **Display Properties** when you are using the display of the computer and an external CRT monitor at the same time.
 - The **Settings** tab is displayed in the following steps;
 - a. Open Control Panel, click Appearance and Themes
 - b. Click display
 - c. Select Settings tab

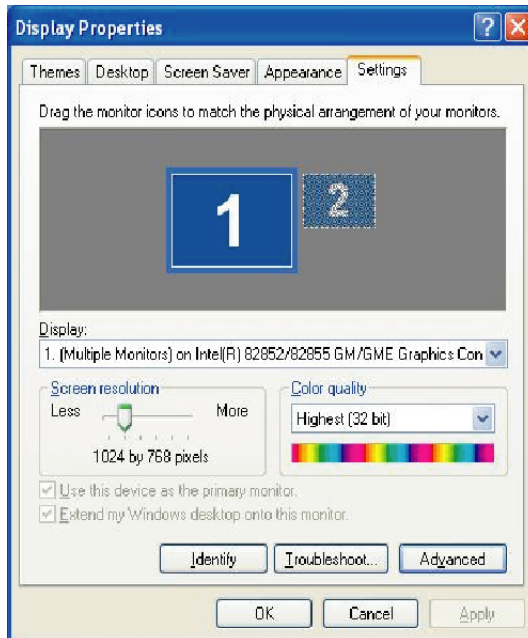

Display Properties

- The way to move to multi-monitor
 - a. Press **Ctrl + Alt + F12** keys to make **Intel® 82852/82855 GM/GME Graphics Controller Prope...** displayed. (See the figure below)
 - b. Click in the left of **Devices** tab (see the figure below), then select **Extended Desktop**.
 - c. Check that the Primary Device is fixed into Note Book (the display of the computer) and the Secondary Device is being fixed into Monitor (CRT display).

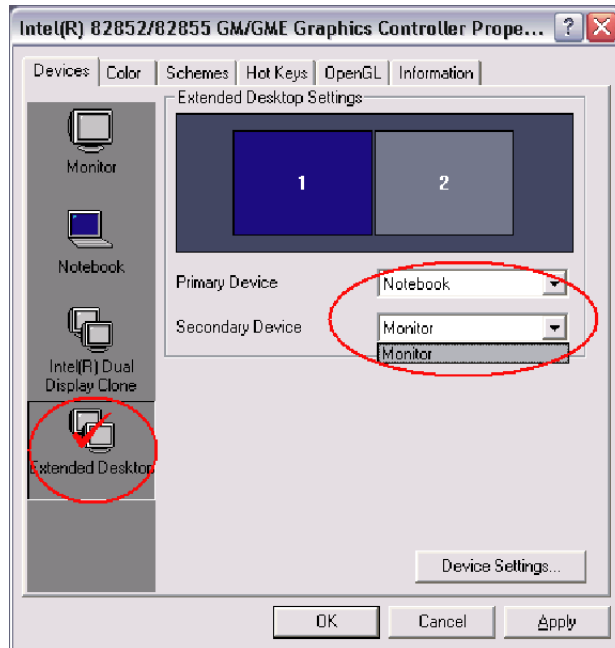

Intel® 82852/82855 GM/GME Graphics Controller Prope...

2. Some reproduced DVD picture may not be displayed when the display of the computer and an external CRT monitor are used at the same. Reduce the resolution, use the display of the computer only, use the CRT monitor only or set display device in the multi-monitor, then play DVD.

Please refer to *External monitor* in the online manual of Chapter 8, *Optional Devices*, or the application guide for the setting of each display device.

3. The reproduced picture may be up and down slightly in some DVD titles when reproduced by WinDVD 4.0. The swing can be suppressed by the following procedure:
- Boot up WinDVD 4.0 and click the circled part shown in the figure below, then select **Display** out of the list.



WinDVD 4.0

- The following sub-panel is displayed, then click the circled part shown in the figure below.



WinDVD 4.0 Sub-panel

- The following **Set up** screen is displayed, then remove the check of **Use Hardware Decode Acceleration** (The check of **Use Hardware Colour Acceleration** is removed automatically).

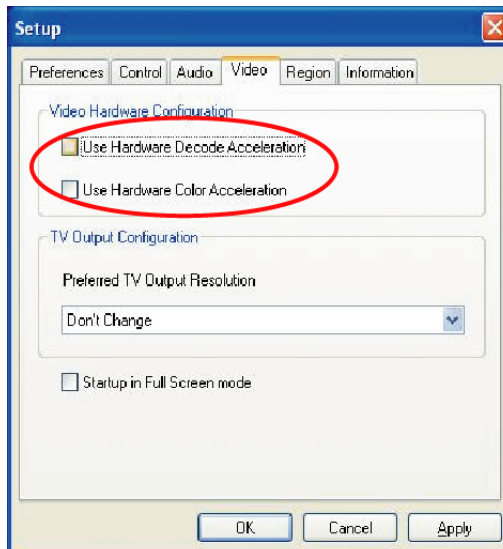

Setup

- Click **OK** button(The **Set up** tab closes automatically).

4. The DVD video overlay is not displayed when the display mode of CRT display is set to high resolution and high refresh rate mode at LCD/CRT simultaneous or multi-monitor.

Please decrease the resolution and refresh rate of CRT display.

5. A DVD-reproduced image may not be displayed in correct position when you press **Fn+F1** to enter into Instant Security mode while a DVD is playing under WinDVD 4.0, and then move the mouse or press the key to exit Instant Security mode. In this case, close WinDVD 4.0 and open it again, or pres the **Stop** button and then the **Play** button to display the DVD image in correct position.

The following steps will work around this problem.

- a. Run WinDVD 4.0. Click the **Subpanel** button and select the **Display** option from the list.
- b. In the **Subpanel** window, click the **Setup** button.
- c. In the **Setup** window, deselect the **Hardware decode acceleration** checkbox (Deselecting this checkbox will automatically deselect the **Hardware colour acceleration** checkbox).
- d. Click the **OK** button (The **Setup** tab panel will close).

If your computer is stolen



Always take care of your computer and try to prevent it from being stolen. You are the owner of a valuable technical device, which may be highly attractive to thieves, so please do not leave it unattended in a public place. To further help protect against theft, security cables can be bought for use with your notebook when it is being used at home or in the office. Make a note of your computer's machine type, model number, and serial number, and put it in a safe place. You will find this information on the underside of your notebook. Please also keep the receipt of the computer you purchased.

Should your computer be stolen, however, we'll help you try to find it. Before contacting TOSHIBA, please prepare the following information which is necessary to uniquely identify your computer:

- In which country was your computer stolen?
- What type of machine do you have?
- What was the model number (PA number)?
- What was the serial number (8 digits)?
- When was it stolen, i.e. date?
- What was the warranty seal number (if available)?
- What is your address, phone, and fax number?

To register the theft, please follow these procedures:

- Fill in the TOSHIBA Theft Registration form (or a copy of it) below.
- Attach a copy of your receipt showing where your computer was purchased.
- Either fax or send the receipt and registration form to the address below.

Your registration will be entered in a database, which is used to track TOSHIBA computers at our service points around Europe.

TOSHIBA Theft Registration

Send to: TOSHIBA Europe GmbH
 Technical Service and Support
 Leibnizstr. 2
 93055 Regensburg
 Germany

Fax number: +49 (0) 941 7807 925

Country stolen:	
Machine type: (e.g. TOSHIBA A40 Series)	
Model number: (e.g. PSA40 YXT)	
Serial number: (e.g. 70123456E)	
Date stolen:	
Warranty seal: (e.g. 9813 123456 049)	

Owner's details

Name:	
Company:	
Street:	
Postal Code/City:	
Country:	
Phone:	
Fax:	

Appendix F

ASCII Character Codes

This appendix shows the American Standard Code for Information Interchange (ASCII) on the following pages. The characters in the **IBM char** column appear on your display when you type the corresponding ASCII code (as described in Chapter 5, *The Keyboard*). The characters that are printed, however, depend on the software you are using. For most software, the printed output for decimal codes 32 to 128 will match your screen display.

Dec code	Hex code	IBM char	Sort seq	Ctrl char
000	00		000	NUL
001	01	☺	1	SOH
002	02	☹	2	STX
003	03	♥	3	ETX
004	04	♦	4	EOT
005	05	♣	5	ENQ
006	06	♠	6	ACK
007	07	•	7	BEL
008	08	■	8	BS
009	09	○	9	HT
010	0A	◼	10	LF
011	0B	♂	11	VT
012	0C	♀	12	FF
013	0D	♪	13	CR
014	0E	🎵	14	SO
015	0F	⚙	15	SI
016	10	▶	16	DLE
017	11	◀	17	DC1
018	12	↕	18	DC2
019	13	!!	19	DC3
020	14	¶	20	DC4
021	15	§	21	NAK
022	16	▬	22	SYN
023	17	↕	23	ETB
024	18	↑	24	CAN
025	19	↓	25	EM
026	1A	→	26	SUB
027	1B	←	27	ESC
028	1C	└	28	FS
029	1D	↔	29	GS
030	1E	▲	30	RS
031	1F	▼	31	US

Dec code	Hex code	IBM char	Sort seq
032	20	space	32
033	21	!	33
034	22	"	34
035	23	#	35
036	24	\$	36
037	25	%	37
038	26	&	38
039	27	'	39
040	28	(40
041	29)	41
042	2A	*	42
043	2B	+	43
044	2C	,	44
045	2D	-	45
046	2E	.	46
047	2F	/	47
048	30	0	48
049	31	1	49
050	32	2	50
051	33	3	51
052	34	4	52
053	35	5	53
054	36	6	54
055	37	7	55
056	38	8	56
057	39	9	57
058	3A	:	58
059	3B	;	59
060	3C	<	60
061	3D	=	61
062	3E	>	62
063	3F	?	63

Dec code	Hex code	IBM char	Sort seq
064	40	@	64
065	41	A	65
066	42	B	66
067	43	C	67
068	44	D	68
069	45	E	69
070	46	F	70
071	47	G	71
072	48	H	72
073	49	I	73
074	4A	J	74
075	4B	K	75
076	4C	L	76
077	4D	M	77
078	4E	N	78
079	4F	O	79
080	50	P	80
081	51	Q	81
082	52	R	82
083	53	S	83
084	54	T	84
085	55	U	85
086	56	V	86
087	57	W	87
088	58	X	88
089	59	Y	89
090	5A	Z	90
091	5B	[91
092	5C	\	92
093	5D]	93
094	5E	^	94
095	5F	_	95

Dec code	Hex code	IBM char	Sort seq
096	60	'	96
097	61	a	97
098	62	b	98
099	63	c	99
100	64	d	100
101	65	e	101
102	66	f	102
103	67	g	103
104	68	h	104
105	69	i	105
106	6A	j	106
107	6B	k	107
108	6C	l	108
109	6D	m	109
110	6E	n	110
111	6F	o	111
112	70	p	112
113	71	q	113
114	72	r	114
115	73	s	115
116	74	t	116
117	75	u	117
118	76	v	118
119	77	w	119
120	78	x	120
121	79	y	121
122	7A	z	122
123	7B	{	123
124	7C		124
125	7D	}	125
126	7E	~	126
127	7F	␣	127

Dec code	Hex code	IBM char	Sort seq
128	80	Ç	67
129	81	ü	85
130	82	é	69
131	83	â	65
132	84	ä	65
133	85	à	65
134	86	å	65
135	87	ç	67
136	88	ê	69
137	89	ë	69
138	8A	è	69
139	8B	ï	73
140	8C	î	73
141	8D	ì	73
142	8E	Ä	65
143	8F	Å	65
144	90	É	69
145	91	æ	65
146	92	Æ	65
147	93	ô	79
148	94	ö	79
149	95	ò	79
150	96	û	85
151	97	ù	85
152	98	ÿ	89
153	99	Ö	79
154	9A	Ü	85
155	9B	ç	36
156	9C	£	36
157	9D	¥	36
158	9E	Pt	36
159	9F	f	36

Dec code	Hex code	IBM char	Sort seq	Dec code	Hex code	IBM char	Sort seq
160	A0	á	65	192	C0	┌	
161	A1	í	73	193	C1	└	
162	A2	ó	79	194	C2	┘	
163	A3	ú	85	195	C3	┐	
164	A4	ñ	78	196	C4	┌	
165	A5	Ñ	78	197	C5	┐	
166	A6	ā	166	198	C6	┘	
167	A7	ō	167	199	C7	┘	
168	A8	ı	63	200	C8	┘	
169	A9	┌	169	201	C9	┘	
170	AA	┌	170	202	CA	┘	
171	AB	½	171	203	CB	┘	
172	AC	¼	172	204	CC	┘	
173	AD	ı	33	205	CD	┘	
174	AE	«	34	206	CE	┘	
175	AF	»	34	207	CF	┘	
176	B0	▣		208	D0	┘	
177	B1	▣		209	D1	┘	
178	B2	▣		210	D2	┘	
179	B3	┌		211	D3	┘	
180	B4	┘		212	D4	┘	
181	B5	┘		213	D5	┘	
182	B6	┘		214	D6	┘	
183	B7	┘		215	D7	┘	
184	B8	┘		216	D8	┘	
185	B9	┘		217	D9	┘	
186	BA	┘		218	DA	┘	
187	BB	┘		219	DB	▣	
188	BC	┘		220	DC	▣	
189	BD	┘		221	DD	▣	
190	BE	┘		222	DE	▣	
191	BF	┘		223	DF	▣	

Dec code	Hex code	IBM char	Sort seq
224	E0	α	
225	E1	β	83
226	E2	Γ	
227	E3	Π	
228	E4	Σ	
229	E5	σ	
230	E6	μ	
231	E7	Υ	
232	E8	Φ	
233	E9	Θ	
234	EA	Ω	
235	EB	δ	
236	EC	ϕ	
237	ED	ϕ	
238	EE	E	
239	EF	Λ	
240	F0	Ξ	
241	F1	\pm	
242	F2	\geq	
243	F3	\leq	
244	F4	\int	
245	F5	J	
246	F6	+	
247	F7	\approx	
248	F8	\circ	
249	F9	■	
250	FA	■	
251	FB	$\sqrt{\quad}$	
252	FC	η	
253	FD	2	
254	FE	■	
255	FF		

Internal Modem Guide

This appendix describes how to install and the remove the internal modem.



Do not disassemble the computer beyond the steps described in this instruction or touch any components not specifically described.

Installing the internal modem



The internal modem is preinstalled. The following is for information only.



Refer to General Precautions for the attention when keyboard brace is removed.

To install the internal modem follow the procedures below.

Installing the modem board and jack

To install the modem board and jack, follow the steps below.

1. Save your data and turn off the computer.
2. Disconnect the AC adaptor and other peripheral devices.
3. Turn the computer upside down and remove the battery pack.
4. Slide the display latch on the front of the computer to the right and open the display panel.
5. Insert your fingernail or a thin object under the rim of the keyboard brace and lift out the brace.
6. Remove two screws securing the keyboard and one screw securing the metal brace. Lift off the metal brace.
7. Lift up the back of the keyboard, rotate it toward you and lay in face down on the palm rest.
8. Lift into the left the insulation sheet covering the modem board and secure the sheet with tape to keep it out of your way.
9. Remove two screws, which you use later to secure the modem board.
10. Connect the modem board cable and seat the modem board.
11. Secure the modem board with two screws removed in step 9.
12. Seat the insulation sheet to cover the modem board.
13. Insert tabs on the front of the keyboard into corresponding notches on the computer and seat the keyboard.
14. Two screws secure the keyboard and one screw secures the metal brace.
15. Seat the keyboard brace and press to secure latches.
16. Install the battery pack. Refer to *Replacing the battery pack* section in Chapter 6, *Power and Power-Up Modes*, for details.

Removing the internal modem

To remove the internal modem, follow the steps below.

1. Save your data and turn off the computer.
2. Disconnect the AC adaptor and other peripheral devices.
3. Turn the computer upside down and remove the battery pack.
4. Slide the display latch on the front of the computer to the right and open the display panel.
5. Insert your fingernail or a thin object under the rim of the keyboard brace and lift out the brace.
6. Remove two screws securing the keyboard and one screw securing the metal brace. Lift off the metal brace.
7. Lift up the back of the keyboard, rotate it toward you and lay in face down on the palm rest.
8. Lift into the left the insulation sheet covering the modem board and secure the sheet with tape to keep it out of your way.
9. Remove two screws and remove the modem board.
10. Disconnect the modem cable.
11. Secure the modem board with two screws removed in step 9.
12. Seat the insulation sheet to cover the modem board.
13. Insert tabs on the front of the keyboard into corresponding notches on the computer and seat the keyboard.
14. Two screws secure the keyboard and one screw secures the metal brace.
15. Seat the keyboard brace and press to secure latches.
16. Install the battery pack. Refer to *Replacing the battery pack* section in Chapter 6, *Power and Power-Up Modes*, for details.

The internal modem is approved by Japan Approvals Institute for Telecommunications Equipment.

Glossary

The terms in this glossary cover topics related to this manual. Alternate naming is included for reference.

A

- adaptor:*** A device that provides an interface between two dissimilar electronic devices. For example, the AC adaptor modifies the power from a wall outlet for use by the computer. This term also refers to the add-in circuit cards that control external devices, such as video monitors and magnetic tape devices.
- allocate:*** To assign a space or function for a specific task.
- alphanumeric:*** Keyboard characters including letters, numbers and other symbols, such as punctuation marks or mathematical symbols.
- alternating current (AC):*** Electric current that reverses its direction of flow at regular intervals.
- analogue signal:*** A signal whose characteristics such as amplitude and frequency vary in proportion to (are an analogue of) the value to be transmitted. Voice communications are analogue signals.
- ANSI:*** American National Standards Institute. An organisation established to adopt and define standards for a variety of technical disciplines. For example, ANSI defined the ASCII standard and other information processing requirements.
- antistatic:*** A material used to prevent the build-up of static electricity.
- application:*** A group of programs that together are used for a specific task such as accounting, financial planning, spreadsheets, word processing, and games, etc.
- ASCII:*** American Standard Code for Information Interchange. ASCII code is a set of 256 binary codes that represent the most commonly used letters, numbers, and symbols.
- async:*** Short for asynchronous.

asynchronous: Lacking regular time relationship. As applied to computer communications, asynchronous refers to the method of transmitting data that does not require a steady stream of bits to be transmitted at regular time intervals.

AUTOEXEC.BAT: A batch file that executes a series of MS-DOS commands and programs each time you start the computer. This is no longer necessarily used when booting Windows NT 4.0 and higher.

B

backup: A duplicate copy of files kept as a spare in case the original is destroyed.

batch file: A file that can be executed from the system prompt containing a sequence of operating system commands or executable files. See also AUTOEXEC.BAT.

billion byte (Bi.B): A unit of data storage equal to 1,000,000,000 bytes. See also million byte.

binary: The base two number system composed of zeros and ones (off or on), used by most digital computers. The right most digit of a binary number has a value of 1, the next a value of 2, then 4, 8, 16, and so on. For example, the binary number 101 has a value of 5. See also ASCII.

BIOS: Basic Input Output System. The firmware that controls data flow within the computer. See also firmware.

bit: Derived from "binary digit," the basic unit of information used by the computer. It is either zero or one. Eight bits is one byte. See also byte.

Bluetooth: A short-range radio technology designed to simplify wireless communication among computers, communication devices and the Internet.

board: A circuit board. An internal card containing electronic components, called chips, which perform a specific function or increase the capabilities of the system.

boot: Short for bootstrap. A program that starts or restarts the computer. The program reads instructions from a storage device into the computer's memory.

bps: Bits per second. Typically used to describe the data transmission speed of a modem.

buffer: The portion of the computer's memory where data is temporarily stored. Buffers often compensate for differences in the rate of flow from one device to another.

bus: An interface for transmission of signals, data or electric power.

byte: The representation of a single character. A sequence of eight bits treated as a single unit; also the smallest addressable unit within the system.

C

cache memory: High speed memory which stores data that increases processor speed and data transfer rate. When the CPU reads data from main memory, it stores a copy of this data in cache memory. The next time the CPU needs that same data, it looks for it in the cache memory rather than the main memory, which saves time. The computer has two cache levels. Level one is incorporated into the processor and level two resides in external memory.

capacity: The amount of data that can be stored on a magnetic storage device such as a diskette (floppy disk) or hard disk. It is usually described in terms of kilobytes (KB), where one KB = 1024 bytes and megabytes (MB), where one MB = 1024 KB.

Card Station II: A device that enables one-point connection to a number of peripheral devices and provides additional ports and slots.

card: Synonym for board. See board.

CardBus: An industry standard bus for 32-bit PC Cards.

CD-R: A Compact Disc-Recordable disc can be written once and read many times. See also CD-ROM.

CD-ROM: A Compact Disc-Read Only Memory is a high capacity disc that can be read from but not written to. The CD-ROM drive uses a laser, rather than magnetic heads, to read data from the disc.

CD-RW: A Compact Disc-Read/Write disc can be rewritten many times.

Centronics: A printer manufacturer whose method of data transmission between a parallel printer and a computer has become an industry standard.

CGA: Colour/graphics adaptor. A video display protocol defined by the IBM Colour/Graphics Monitor Adaptor and its associated circuitry. This protocol supports two-colour 640x200 and four-colour 320x200 graphics, and 16-colour 640x200 and 320x200 text modes.

character: Any letter, number, punctuation mark, or symbol used by the computer. Also synonymous with byte.

chassis: The frame containing the computer.

chip: A small semiconductor containing computer logic and circuitry for processing, memory, input/output functions and controlling other chips.

CMOS: Complementary Metal-Oxide Semiconductor. An electronic circuit fabricated on a silicon wafer that requires very little power. Integrated circuits implemented in CMOS technology can be tightly packaged and are highly reliable.

cold start: Starting a computer that is currently off (turning on the power).

COM1, COM2, COM3 and COM4: The names assigned to the serial and communication ports.

commands: Instructions you enter at the terminal keyboard that direct the actions of the computer or its peripheral devices.

communications: The means by which a computer transmits and receives data to and from another computer or device.

Compact Flash: A small removable mass storage device, designed with flash technology, a non-volatile storage solution that does not require a battery to retain data indefinitely.

compatibility: 1) The ability of one computer to accept and process data in the same manner as another computer without modifying the data or the media upon which it is being transferred. 2) the ability of one device to connect to or communicate with another system or component.

components: Elements or parts (of a system) which make up the whole (system).

computer program: A set of instructions written for a computer that enable it to achieve a desired result.

computer system: A combination of hardware, software, firmware, and peripheral components assembled to process data into useful information.

configuration: The specific components in your system (such as the terminal, printer, and disk drives) and the settings that define how your system works. You use the HW Setup program to configure your system.

control keys: A key or sequence of keys you enter from the keyboard to initiate a particular function within a program.

controller: Built-in hardware and software that controls the functions of a specific internal or peripheral device (e.g. keyboard controller).

CPS: Characters per second. Typically used to indicate the transmission speed of a printer.

CPU: Central processing unit. The portion of the computer that interprets and executes instructions.

CRT: Cathode Ray Tube. A vacuum tube in which beams projected on a fluorescent screen-producing luminous spots. An example is the television set.

cursor: A small, blinking rectangle or line that indicates the current position on the display screen.

D

data bits: A data communications parameter controlling the number of bits (binary digits) used to make up a byte. If data bits = 7 the computer can generate 128 unique characters. If data bits = 8 the computer can generate 256 unique characters.

data: Information that is factual, measurable or statistical that a computer can process, store, or retrieve.

DC: Direct Current. Electric current that flows in one direction. This type of power is usually supplied by batteries.

default: The parameter value automatically selected by the system when you or the program do not provide instructions. Also called a preset value.

delete: To remove data from a disk or other data storage device. Synonymous with erase.

Desk Station V Plus: An expansion device that provides the computer with additional ports, slots and bays.

device driver: A program that controls communication between a specific peripheral device and the computer. The CONFIG.SYS file contains device drivers that MS-DOS loads when you turn the computer on.

dialog box: A Windows element that requires the user to provide further information, such as number of copies to print.

disk drive: The device that randomly accesses information on a disk and copies it to the computer's memory. It also writes data from memory to the disk. To accomplish these tasks, the unit physically rotates the disk at high speed past a read-write head.

disk storage: Storing data on magnetic disk. Data is arranged on concentric tracks much like a phonograph record.

diskette: A removable disk that stores magnetically encoded data used on a microcomputer. Also called floppy disk.

display: A CRT, plasma screen, LCD, or other image producing device used to view computer output.

documentation: The set of manual and/or other instructions written for the users of a computer system or application. Computer system documentation typically includes procedural and tutorial information as well as system functions.

DOS: Disk Operating System. See operating system.

driver: A software program, generally part of the operating system, that controls a specific piece of hardware (frequently a peripheral device such as a printer or mouse).

dual-scan supertwisted nematic (DSTN) display: A thin-screen, passive matrix colour LCD that meets VGA standards.

DVD-R: A Digital Versatile Disc-Recordable disk can be written once and read many times.

DVD-RAM: A Digital Versatile Disc Random Access Memory is a high-capacity, high performance disc that lets you store large volumes of data. The DVD drive uses a laser to read data from the disc.

DVD-ROM: A Digital Versatile Disc Read Only Memory is a high capacity, high performance disc suitable for play back of video and other high-density files. The DVD drive uses a laser to read data from the disc.

DVD-RW: A Digital Versatile Disc-Read/Write disc can be rewritten many times.

DVD±RW: A Digital Versatile Disc±Read/Write disc can be rewritten many times.

E

echo: To send back a reflection of the transmitted data to the sending device. You can display the information on the screen, or output it to the printer, or both. When a computer receives back data it transmitted to a CRT (or other peripheral device) and then retransmits the data to printer, the printer is said to echo the CRT.

EGA: Enhanced Graphics Adaptor. A video display protocol defined by the IBM Enhanced Graphics Adaptor and its associated circuitry for direct drive TTL displays that supports 16-colour/monochrome 640x350 and 16-colour 640x200 and 320x200 graphics, and 16-colour 640x350 and 320x350 text modes.

erase: See delete.

escape guard time: A time before and after an escape code is sent to the modem which distinguishes between escapes that are part of the transmitted data, and escapes that are intended as a command to the modem.

escape: 1) A code (ASCII code 27), signalling the computer that what follows are commands; used with peripheral devices such as printers and modems. 2) A means of aborting the task currently in progress.

execute: To interpret and execute an instruction.

Extended Capability Port: An industry standard that provides a data buffer, switchable forward and reverse data transmission, and run length encoding (RLE) support.

F

- fast infrared:** An industry standard that enables cableless infrared serial data transfer at speeds of up to 4 Mbps.
- file:** A collection of related information; a file can contain data, programs, or both.
- firmware:** A set of instructions built into the hardware which controls and directs a microprocessor's activities.
- fixed disk:** See hard disk.
- floppy disk drive (FDD):** An electromechanical device that reads and writes to floppy disks. See also diskette.
- floppy disk:** See diskette.
- folder:** An icon in Windows used to store documents or other folders.
- format:** The process of readying a blank disk for its first use. Formatting establishes the structure of the disk that the operating system expects before it writes files or programs onto the disk.
- function keys:** The keys labelled **F1** through **F12** that tell the computer to perform certain functions.

G

- gigabyte (GB):** A unit of data storage equal to 1024 megabytes. See also megabyte.
- GND:** Ground. An RS-232C signal used in the exchange of data between a computer and serial device.
- graphics:** The use of drawings, pictures, or other images, such as charts or graphs, to present information.

H

- hard disk drive (HDD):** An electromechanical device that reads and writes a hard disk. See also hard disk.
- hard disk:** A non-removable disk usually referred to as drive C. The factory installs this disk and only a trained engineer can remove it for servicing. Also called fixed disk.
- hardware:** The physical electronic and mechanical components of a computer system: typically, the computer itself, external disk drives, etc. See also software and firmware.
- HW Setup:** A TOSHIBA utility that lets you set the parameters for various hardware components.

hertz: A unit of wave frequency that equals one cycle per second.

hexadecimal: The base 16 numbering system composed of the digits 0 through 9 and the letters A, B, C, D, E, and F.

host computer: The computer that controls, regulates, and transmits information to a device or another computer.

hotkey: A TOSHIBA feature in which certain keys in combination with the extended function key, **Fn**, can be used to set system parameters, such as speaker volume.

I/O devices: Equipment used to communicate with the computer and transfer data to and from it.

I/O: Input/output. Refers to acceptance and transfer of data to and from a computer.

icon: A small graphic image displayed on the screen or in the indicator panel. In Windows, an icon represents an object that the user can manipulate.

i.LINK (IEEE1394): This port enables high-speed data transfer directly from external devices such as digital video cameras.

infrared port: A cableless communications port capable of using infrared signals to send serial data.

input: The data or instructions you provide to a computer, communication device or other peripheral device from the keyboard or external or internal storage devices. The data sent (or output) by the sending computer is input for the receiving computer.

instruction: Statements or commands that specify how to perform a particular task.

interface: 1) Hardware and/or software components of a system used specifically to connect one system or device to another. 2) To physically connect one system or device to another to exchange information. 3) The point of contact between user, the computer, and the program, for example, the keyboard or a menu.

interrupt request: A signal that gives a component access to the processor.

IrDA 1.1: An industry standard that enables cableless infrared serial data transfer at speeds of up to 4 Mbps.

J

jumper: A small clip or wire that allows you to change the hardware characteristics by electrically connecting two points of a circuit.

K

K: Taken from the Greek word kilo, meaning 1000; often used as equivalent to 1024, or 2 raised to the 10th power. See *also* byte and kilobyte.

KB: See kilobyte.

keyboard: An input device containing switches that are activated by manually pressing marked keys. Each keystroke activates a switch that transmits a specific code to the computer. For each key, the transmitted code is, in turn, representative of the (ASCII) character marked on the key.

kilobyte (KB): A unit of data storage equal to 1024 bytes. See *also* byte and megabyte.

L

level 2 cache: See cache.

Light Emitting Diode (LED): A semiconductor device that emits light when a current is applied.

Liquid Crystal Display (LCD): Liquid crystal sealed between two sheets of glass coated with transparent conducting material. The viewing-side coating is etched into character forming segments with leads that extend to the edge of the glass. Applying a voltage between the glass sheets alters the brightness of the liquid crystal.

LSI: Large Scale Integration. 1) A technology that allows the inclusion of up to 100,000 simple logic gates on a single chip. 2) An integrated circuit that uses the large scale integration.

M

- magiCDisc:** A TOSHIBA utility that lets you create a CD-ROM data base for quick access to CD-ROM data.
- main board:** See motherboard.
- maths co-processor:** A circuit built into the processor that is dedicated to intensive math calculations.
- MDA:** Monochrome Display Adaptor. A video display protocol defined by the IBM Monochrome Display Adaptor and its associated circuitry for direct drive TTL displays that supports a monochrome 720x350 text mode.
- megabyte (MB):** A unit of data storage equal to 1024 kilobytes. See also kilobyte.
- megahertz:** A unit of wave frequency that equals 1 million cycles per second. See also hertz.
- Memory Stick:** An IC recording media designed to record various kinds of digital content such as still and moving images, music and computer data on a single stick.
- menu:** A software interface that displays a list of options on the screen. Also called a screen.
- microprocessor:** A hardware component contained in a single integrated circuit that carries out instructions. Also called the central processing unit (CPU), one of the main parts of the computer.
- million byte:** A unit of data storage equal to 1,000,000 bytes.
- MMX:** Refers to microprocessors with additional instructions beyond the x86 standard. The instructions were developed on the basis of multimedia code requirements and thus improve the performance of multimedia applications.
- mode:** A method of operation, for example, the boot mode, standby mode or the hibernation mode.
- modem:** Derived from modulator/demodulator, a device that converts (modulates) digital data for transmission over telephone lines and then converts modulated data (demodulates) to digital format where received.
- monitor:** A device that uses rows and columns of pixels to display alphanumeric characters or graphic images. See CRT.
- motherboard:** A name sometimes used to refer to the main printed circuit board in processing equipment. It usually contains integrated circuits that perform the processor's basic functions and provides connectors for adding other boards that perform special functions. Sometimes called a main board.
- MPEG:** Moving picture coding expert group is an industry standard architecture for compression of video signals.
- MP3:** An audio compression standard that enables high-quality transmission and real-time playback of sound files.

N

non-system disk: A formatted diskette (floppy disk) you can use to store programs and data but you cannot use to start the computer. See system disk.

non-volatile memory: Memory, usually read-only (ROM), that is capable of permanently storing information. Turning the computer's power off does not alter data stored in non-volatile memory.

numeric keypad overlay: A feature that allows you to use certain keys on the keyboard to perform numeric entry, or to control cursor and page movement.

O

OCR: Optical Character Recognition (reader). A technique or device that uses laser or visible light to identify characters and input them into a storage device.

OCR wand: A device that reads, using an optical device, hand written or machine printed symbols into a computer. See also OCR.

on-line state: A functional state of a peripheral device when it is ready to receive or transmit data.

operating system: A group of programs that controls the basic operation of a computer. Operating system functions include interpreting programs, creating data files, and controlling the transmission and receipt (input/output) of data to and from memory and peripheral devices.

output: The results of a computer operation. Output commonly indicates data 1) printed on paper, 2) displayed at a terminal, 3) sent through the serial port of internal modem, or 4) stored on some magnetic media.

P

- parallel interface:** Refers to a type of information exchange that transmits information one byte (8 bits) at a time. See also serial interface.
- parallel:** Refers to two or more processes or events that can occur simultaneously, and without interfering with each other. See also serial.
- parity:** 1) The symmetrical relationship between two parameter values (integers) both of which are either on or off; odd or even; 0 or 1.
2) In serial communications, an error detection bit that is added to a group of data bits making the sum of the bits even or odd. Parity can be set to none, odd, or even.
- password:** A unique string of characters used to identify a specific user. The computer provides various levels of password protection such as user, supervisor and eject.
- pel:** The smallest area of the display that can be addressed by software. Equal in size to a pixel or group of pixels. See pixel.
- peripheral component interconnect:** An industry standard 32-bit bus.
- peripheral device:** An I/O device that is external to the central processor and/or main memory such as a printer or a mouse.
- pixel:** A picture element. The smallest dot that can be made on a display or printer. Also called a pel.
- port replicator:** See Card Station II.
- port:** The electrical connection through which the computer sends and receives data to and from devices or other computers.
- Power Saver Utility:** A TOSHIBA utility that lets you set the parameters for various power-saving functions.
- printed circuit board (PCB):** A hardware component of a processor to which integrated circuits and other components are attached. The board itself is typically flat and rectangular, and constructed of fibreglass, to form the attachment surface.
- program:** A set of instructions a computer can execute that enables it to achieve a desired result. See also application.
- prompt:** A message the computer provides indicating it is ready for or requires information or an action from you.

R

Radio frequency interference (RFI) shield: A metal shield enclosing the printed circuit boards of the printer or computer to prevent radio and TV interference. All computer equipment generates radio frequency signals. The FCC regulates the amount of signals a computing device can allow past its shielding. A Class A device is sufficient for office use. Class B provides a more stringent classification for home equipment use. TOSHIBA portable computers comply with Class B computing device regulations.

RAMDRIVE: Part of the computer's random access memory assigned to simulate a disk. RAMDRIVE is a feature of MS-DOS.

Random Access Memory (RAM): High speed memory within the computer circuitry that can be read or written to.

RCA jack: A single-pin connector that carries composite video signals, which include both contrast and colour information. *See also* S-video.

restart: Resetting a computer without turning it off (also called 'warm boot' or 'soft reset'). To restart the computer, press **Ctrl + Alt + Del** while the computer is on. *See also* boot.

resume: A feature that lets you turn off the power without first exiting a program and retain your data in RAM. When you turn on the computer, the screen appears the same as when you turned it off. Also called standby in Windows 98.

RGB: Red, green, and blue. A device that uses three input signals, each activating an electron gun for a primary additive colour (red, green, and blue) or port for using such a device. *See also* CRT.

RJ11: A modular telephone jack.

ROM: Read Only Memory: A non-volatile memory chip manufactured to contain information that controls the computer's basic operation. You cannot access or change information stored in ROM.

RS-232C: The Electronic Industries Association (EIA) interface standard that describes the 25-pin connector interface and control, data, and status signals that allow asynchronous communications between computers, printers, communications and other peripheral devices.

S

- SCSI:** Small Computer System Interface is an industry standard interface for connection of a variety of peripheral devices.
- SD cards:** Secure Digital cards are flash memory widely used in a variety of digital devices such as digital cameras and Personal Digital Assistants.
- serial port:** A communications port to which you can connect devices, such as a modem, mouse, or serial printer.
- serial:** The handling of data bits one after the other.
- SIO:** Serial Input/Output. The electronic methodology used in serial data transmission.
- Smart media:** A storage card of about one-thirds of the area of a conventional PC card and only 0.76mm thickness. It can be used in equipment that requires a removable memory chip for portability.
- soft key:** Key combinations that emulate keys on the IBM keyboard, change some configuration options, stop program execution, and access the numeric keypad overlay.
- software:** The set of programs, procedures and related documentation associated with a computer system. Specifically refers to computer programs that direct and control the computer system's activities. *See also* hardware.
- standby:** *See* resume.
- stop bit:** One or more bits of a byte that follow the transmitted character or group codes in asynchronous serial communications.
- subpixel:** Three elements, one red, one green and blue (RGB), that make up a pixel on the colour LCD. The computer sets subpixels independently, each may emit a different degree of brightness. *See also* pixel.
- suspend:** *See* resume.
- S-video:** This connection provides separate lines for contrast and colour, which produces a video image superior to that produced by a composite connection. *See also* RCA jack.
- synchronous:** Having a constant time interval between successive bits, characters or events.
- system disk:** A disk that has been formatted with an operating system. For MS-DOS the operating system is contained in two hidden files and the COMMAND.COM file. You can boot a computer using a system disk. Also called an operating system disk.

T

- terminal:** A typewriter-like keyboard and CRT display screen connected to the computer for data input/output.
- TFT:** Thin-film transistor. A colour LCD technology that applies individual transistors to each pixel enabling fine display control and excellent screen legibility.
- touch pad:** A pointing device integrated into the TOSHIBA computer palm rest.
- TTL:** Transistor-transistor logic. A logic circuit design that uses switching transistors for gates and storage.

U

- USB:** The *Universal Serial Bus* is a way to connect up to 127 devices through one connector. A new development in 1997, this offers significantly improved ease of use and reliability than earlier expansion methods.

V

- VGA:** Video Graphics Array is an industry standard video adaptor that lets you run any popular software.
- volatile memory:** Random access memory (RAM) that stores information as long as the computer is connected to a power source.

W

- warm start:** Restarting or resetting a computer without turning it off.
- window:** A portion of the screen that can display its own application or document. Often used to mean a Microsoft Windows window.
- wireless LAN:** Local Area Network (LAN) through wireless communication. A short-range radio technology designed to simplify wireless communication with other LAN systems based on Direct Sequence Spread Spectrum radio technology that complies with the IEEE 802.11 Standard (Revision B).
- write protection:** A method for protecting a diskette (floppy disk) from accidental erasure.

Z

- ZV port:** Zoomed Video port dedicated to high-performance video data transfer.

Index

A

- AC adaptor, 1-4, 2-17, 8-10
 - connecting, 3-5
- AC power
 - problems, 9-5
- ASCII characters, 5-8, F-1
- Audio/Video
 - control buttons, 2-10
 - controls, 4-6

B

- Battery, 1-4
 - care and use of, 6-5
 - charging, 6-8
 - charging notice, 6-9
 - charging time, 6-9
 - extending life, 6-11
 - indicator, 6-2
 - installing, 6-14
 - monitoring capacity, 6-10
 - operating time, 6-9
 - pack, 2-8, 6-4, 8-10
 - problems, 9-6
 - real time clock, 6-5
 - removing, 6-12
 - replacing, 6-12
 - RTC, 1-4
 - safety precautions, 6-5
 - saving power, 6-10
 - system indicator, 2-11
 - types, 6-4
- Boot Priority, 7-7

C

- CD-RW/DVD-ROM, 2-16
 - problems, 9-11
- Certification, A-3
- Certification agencies, B-1
- Cleaning the computer, 4-20
- computer
 - cleaning, 4-20
 - moving, 4-21
 - cooling, 1-10, 4-21
- CPU, 7-6

D

- DC IN 15V, 2-6
 - indicator, 6-3
- Device Config, 7-4
- Diskette drive
 - problems, 9-14
- Disks, 1-5
- Display, 1-6, 7-5
 - controller, D-1
 - opening, 3-6
- Documentation, 1-2
- DVD-R/-RW, 2-16
 - problems, 9-13

E

- Environmental Requirements, A-1
- External monitor, 8-10
 - port, 1-6, 2-5
 - problems, 9-18

F

- Fn + Ctrl, 5-3
- Fn + Enter, 5-3
- Fn + Esc (Sound mute), 5-4
- Fn + F1 (Instant security), 5-4
- Fn + F10 (Arrow mode), 5-3
- Fn + F11 (Numeric mode), 5-3
- Fn + F12 (ScrLock), 5-3
- Fn + F2 (Power save mode), 5-4
- Fn + F3 (Standby), 5-4
- Fn + F4 (Hibernation), 5-4
- Fn + F5 (display selection), 5-5
- Fn + F6 (Display Brightness), 5-5
- Fn + F7 (Display Brightness), 5-5
- Fn + F9 (Touch pad), 5-5
- Fn+F10 (Arrow mode), 5-7
- Fn+F11 (Numeric mode), 5-7

H

- Hard disk drive
 - problems, 9-11
- Hardware, 1-1
- Headphone
 - jack, 2-5
- Hot keys, 5-4
- Hotkeys
 - Arrow mode, 5-3
 - Display Brightness, 5-5
 - display selection, 5-5
 - Hibernation, 5-4
 - Instant security, 5-4
 - Numeric mode, 5-3
 - Power save mode, 5-4
 - ScrLock, 5-3
 - Sound mute, 5-4
 - Standby, 5-4
 - Touch pad, 5-5
- HW Setup, 7-1
 - Boot Priority, 7-7
 - CPU, 7-6
 - Device Config, 7-4
 - Display, 7-5
 - Keyboard, 7-9
 - LAN, 7-10
 - Parallel/Printer, 7-5
 - Password, 7-2
 - USB, 7-9

I

- Instant security, 1-9

K

- Keyboard, 1-6, 7-9
 - F1...F12 function keys, 5-2
 - indicators, 2-12
 - problems, 9-7
 - Typewriter keys, 5-1
 - Windows special keys, 5-6
- Keypad overlay, 5-7

L

- LAN, 1-7, 4-19, 7-10
 - connecting, 4-19
 - disconnecting, 4-20
 - jack, 2-2
 - problems, 9-20
- LCD panel
 - problems, 9-10

M

- Media care, 4-13
- Memory, 1-4, 8-4
 - installing, 8-5
 - problems, 9-17
 - removing, 8-9
 - Video RAM, 1-4
- Microphone
 - jack, 2-5
- Modem, 1-7, 4-16
 - built-in, A-2
 - connecting, 4-18
 - disconnecting, 4-18
 - jack, 2-4
 - problems, 9-19
- Moving the computer, 4-21
- Multimedia, 1-7

N

- Numeric keypad, 5-7

O

- Operating System, 1-8
- Optical media drive, 2-4, 2-14
 - CD-RW/DVD-ROM, 2-16
 - DVD-R/-RW, 2-16
 - safety instructions, iv
 - using, 4-2
- overheating
 - problems, 9-5

P

- Panel power on, 6-16
- Parallel port, 1-6, 2-5
- Parallel printer, 8-11
- Parallel/Printer, 7-5
- Password, 7-2
 - power on, 1-9
 - problems, 9-7
 - starting the computer by, 6-15
 - supervisor, 7-10
- PC card, 8-2
 - inserting, 8-2
 - problems, 9-15
 - removing, 8-3
 - slot, 1-6, 2-3
- Plug and Play, 1-8
- Pointing device
 - problems, 9-15
- Ports
 - DC IN 15V, 2-6
 - External monitor, 1-6, 2-5
 - Headphone, 2-5
 - LAN, 2-2
 - Microphone, 2-5
 - Modem, 2-4
 - Parallel, 1-6, 2-5
 - PC card, 1-6, 2-3
 - USB, 1-6, 2-3, 2-6
- Power, 1-4
 - button, 2-10
 - conditions, 6-1
 - display automatic power off, 1-8
 - hibernation, 3-8
 - Hibernation, 1-10
 - indicator, 6-3
 - indicators, 6-2
 - panel power on/off, 6-16
 - standby, 3-10
 - Standby, 1-10
 - system automatic power off, 1-8
 - system indicator, 2-11
 - turning off, 3-8
 - turning on, 3-7
- Power-up modes, 6-15
- Printer
 - problems, 9-21

Problems, 9-1

- AC power, 9-5
 - analysing symptoms, 9-2
 - Battery, 9-6
 - CD-RW/DVD-ROM drive, 9-11
 - Diskette drive, 9-14
 - DVD-R/-RW drive, 9-13
 - External Monitor, 9-18
 - Hard disk drive, 9-11
 - hardware and system checklist, 9-3
 - initial precautions, 9-1
 - Keyboard, 9-7
 - LAN, 9-20
 - LCD panel, 9-10
 - Memory, 9-17
 - Modem, 9-19
 - overheating, 9-5
 - Password, 9-7
 - PC card, 9-15
 - Pointing device, 9-15
 - power sources, 9-4
 - preliminary checklist, 9-2
 - Printer, 9-21
 - Real time clock, 9-20
 - self test, 9-4
 - Sound system, 9-18
 - support from TOSHIBA, 9-22
 - system start-up, 9-4
 - USB, 9-17
- Processor, 1-3

R

- Real time clock
 - battery, 6-5
- Real Time Clock
 - problems, 9-20
- restarting the computer, 3-12
- Retaining data with power off, 6-11

S

- Security lock, 1-13, 2-6, 8-12
- Self Test, 9-4
- Soft keys, 5-2
 - Alt Gr Key Combinations, 5-2
- Software, 1-2
- Sound system, 4-14
 - problems, 9-18
- Specifications, A-1
- Stereo speakers, 2-10
- Supervisor password, 7-10
- System indicators, 2-1, 2-11
 - Battery, 2-11
 - DC IN 15V, 2-11
 - HDD, 2-11
 - Power, 2-11

T

- Toshiba Utilities, 1-8
- Touch pad, 1-6, 2-10
 - control buttons, 2-10
 - using, 4-1
- Troubleshooting, 9-1

U

- USB, 7-9
 - diskette drive, 8-10
 - ports, 1-6, 2-3, 2-6
 - problems, 9-17

V

- Video modes, D-1
- Video RAM, 1-4
- Volume control, 2-5, 4-14

W

- Writable discs, 2-15
- Writing CD/DVDs, 4-7, 4-9
 - Drag'n Drop CD+DVD, 4-12